

HYDRAULIC EXCAVATOR

TB260

TAKEUCHITM
From World First to World Leader



Operating Weight: 5,735 kg

Product Features & Specifications

ENGINE

- EU Stage V / EPA Tier 4 Emission Compliant (4TNV86CT)
- EU Stage IIIA Emission Compliant (4TNV84T)
- Turbocharged
- DOC + DPF Exhaust After Treatment (4TNV86CT)
- Automatic Fuel Bleed System
- Double Element, Air Cleaner
- Automatic Deceleration
- Working Modes: Standard, ECO and High Altitude
- Engine Preheat
- High Capacity Radiator and Hydraulic Oil Cooler
- High Capacity Fuel Filters
- Extended Life Coolant
- Engine Safety Start System on the Left Console
- Engine Auto Stop
- Fuel Supply Pump (optional)

WORKING EQUIPMENT

- Independent Mono Boom Swing
- Cushioned Boom, Arm and Swing Cylinder
- 1,620 mm Arm
- 1,780 mm Arm
- Boom Holding Valve with Lift Alarm
- Arm Holding Valve (optional)
- Pattern Change Valve (ISO or G) (optional)
- Boom Swing Stopper (optional)

OPERATOR'S STATION

- ROPS / OPG (TOP Guard, Level I)
- Deluxe High Back Suspension Seat with Head Rest
- 2" Retractable Seat Belt
- Rain Guard (Cab optional)
- OPG Level II Roof Guard Kit (Cab optional)
- OPG Level II Front Guard (Cab optional)
- Cab with Air Conditioner, Heat Defrost, Windshield Wiper and Washer, Skylight with Sunshade, AM / FM / MP3 Bluetooth, 12v Power Outlet

UNDERCARRIAGE AND FRAME

- Triple Flanged Track Rollers
- 2-Speed Travel with Automatic Shift
- High Torque Planetary Final Drive
- Heavy Duty Dozer Blade with Float (optional)
- Power Angle Blade with Float and Bolt-on Cutting Edge (optional)
- Large Wraparound Counterweight
- 400 mm Rubber Crawlers
- 400 mm Steel Crawlers (optional)
- 400 mm Segmented Rubber Crawlers (optional)
- Rubber Pads for 400 mm Steel Crawlers (optional)

TAKEUCHI FLEET MANAGEMENT

- Minimize Downtime
- Remote Diagnostics
- Utilization Tracking
- Proactive Maintenance
- Control Costs

HYDRAULIC

- Variable Displacement Pump
- Straight Travel Circuit
- Hydraulic Joystick Controls
- Proportional Control for Service Port 1
- Detent for Service Port 1
- Proportional Control for Service Port 2
- Service Port 3 for Quick Hitch (optional)
- Proportional Control for Service Port 4 (optional)
- Adjustable Auxiliary Flow for Service Port 1, 2, and 4
- Hydraulic Selector Valve (1-way / 2-way)
- Auto Pressure Release (optional)
- Air Breather, Hydraulic Tank
- Auto Tank (optional)
- Pilot Accumulator

ELECTRICAL

- LCD Multi-Informational Display (Canopy)
- 5.7" Color Multi-Informational Display (Cab)
- Sealed Rocker Switches
- 12 volt System with 55 amp Alternator
- Rear View Camera (optional)
- LED Light Package 1; Front Cover, Boom and Front Cab (optional)
- LED Light Package 2; Front Cover, Boom, Front Cab and Rear Cab (optional)
- Beacon Socket and Lamp Switch (Cab Only)
- TFM (Takeuchi Fleet Management; GPS)*
- TSS (Takeuchi Security System; Immobilizer) (optional)*
- Travel Alarm (optional)



Spacious Cabin



Automotive Styled Interior

*Functions may not be available in all countries, so please consult your Takeuchi dealer for details.

TOUGH, POWERFUL, RELIABLE



Large Floor with Foot Rest



Wraparound Counterweight



Triple Flanged Track Rollers

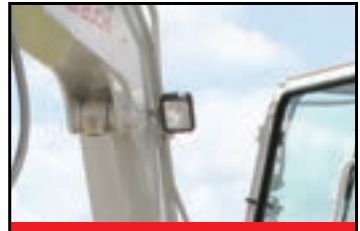

Work Lights

Known for its dependability and outstanding performance in the field, the TB260 offers lockable service access panels, automotive styled interior, and a smooth and powerful hydraulic system. Primary and secondary auxiliary hydraulic circuits and a high capacity hydraulic system make the TB260 an excellent attachment platform.

An optional pattern change valve is located under the side cover and allows the operator to choose their preferred operational control pattern before entering the machine.

Once in the cabin the operator will enjoy a deluxe high back suspension seat, a spacious interior that is comfortable and includes conveniently positioned rocker switches to control additional functions, and the dial throttle allows the operator to control engine speed effortlessly.

Additional features include automatic idle, heavy duty cooling module, and a large wraparound counterweight that protects engine components from damage.



Large lockable service hoods provide vandalism protection and outstanding maintenance access.

OPERATING PERFORMANCE	Serial No. 126000002 or later	Serial No. 126100003 or later
Operating Weight - Cab	5,735 kg	
Operating Weight - Canopy	N/A	5,500 kg
Bucket Capacity (Heaped)	0.168 m ³	
Slew Speed	9.4 min ⁻¹	
Travel Speed		
1st	2.8 km/h	
2nd	4.9 km/h	
Gradeability	30°	
Ground Pressure - Cab	31.5 kPa	
Ground Pressure - Canopy	N/A	30.2 kPa
Maximum Bucket Breakout Force	43.2 kN	
Maximum Arm Digging Force (1,620 mm Arm)	27.3 kN	
Maximum Arm Digging Force (1,780 mm Arm)	25.6 kN	
Traction Force	66.9 kN	
Boom Swing Angle (Left/Right)	78° / 55°	

ENGINE		
Model	Yanmar 4TNV84T	Yanmar 4TNV86CT
Rated Output (ISO 14396)	34.3 kW / 2,400 min ⁻¹	35.5 kW / 2,400 min ⁻¹
Maximum Torque	160.8 Nm 1,700 min ⁻¹	177.0 Nm 1,560 min ⁻¹
Displacement	1,995 ml 2,091 ml	
Alternator	12 V - 0.66 kW	
Battery (IEC 60095-1)	12 V - 90 A·h	

FLUID CAPACITY	
Engine Lubrication	7.4 L
Cooling System	11.0 L
Fuel Tank Capacity	81.0 L
Hydraulic Reservoir Capacity	49.0 L
Hydraulic System Capacity	90.0 L

HYDRAULIC SYSTEM	Serial No. 126000002 or later	Serial No. 126100003 or later
P1, P2	Variable Displacement Pump	
Flow Rate	58.3 L/min	
Relief Pressure	24.0 MPa	
P3	Gear Pump	
Flow Rate	43.9 L/min	
Relief Pressure	20.6 MPa	
Service Port 1		
Flow Rate	102.2 L/min	
Hydraulic Pressure	20.6 MPa	
Service Port 2		
Flow Rate	43.9 L/min	
Hydraulic Pressure	20.6 MPa	
Service Port 3		
Hydraulic Pressure	20.6 MPa	
Service Port 4		
Flow Rate	43.9 L/min	
Hydraulic Pressure	20.6 MPa	

SAFETY and HEALTH		
Vibration Levels		
Hand / Arm	≤ 2.5 m/s ²	
Body	≤ 0.5 m/s ²	
Noise Level		
Sound Power Level	L _{WA} 97 dB	



Hydraulic Joystick Controls



Multi-Informational Display



Auxiliary Hydraulic Lines



Multi-Function Switch Bank

TB260 Compact Excavator

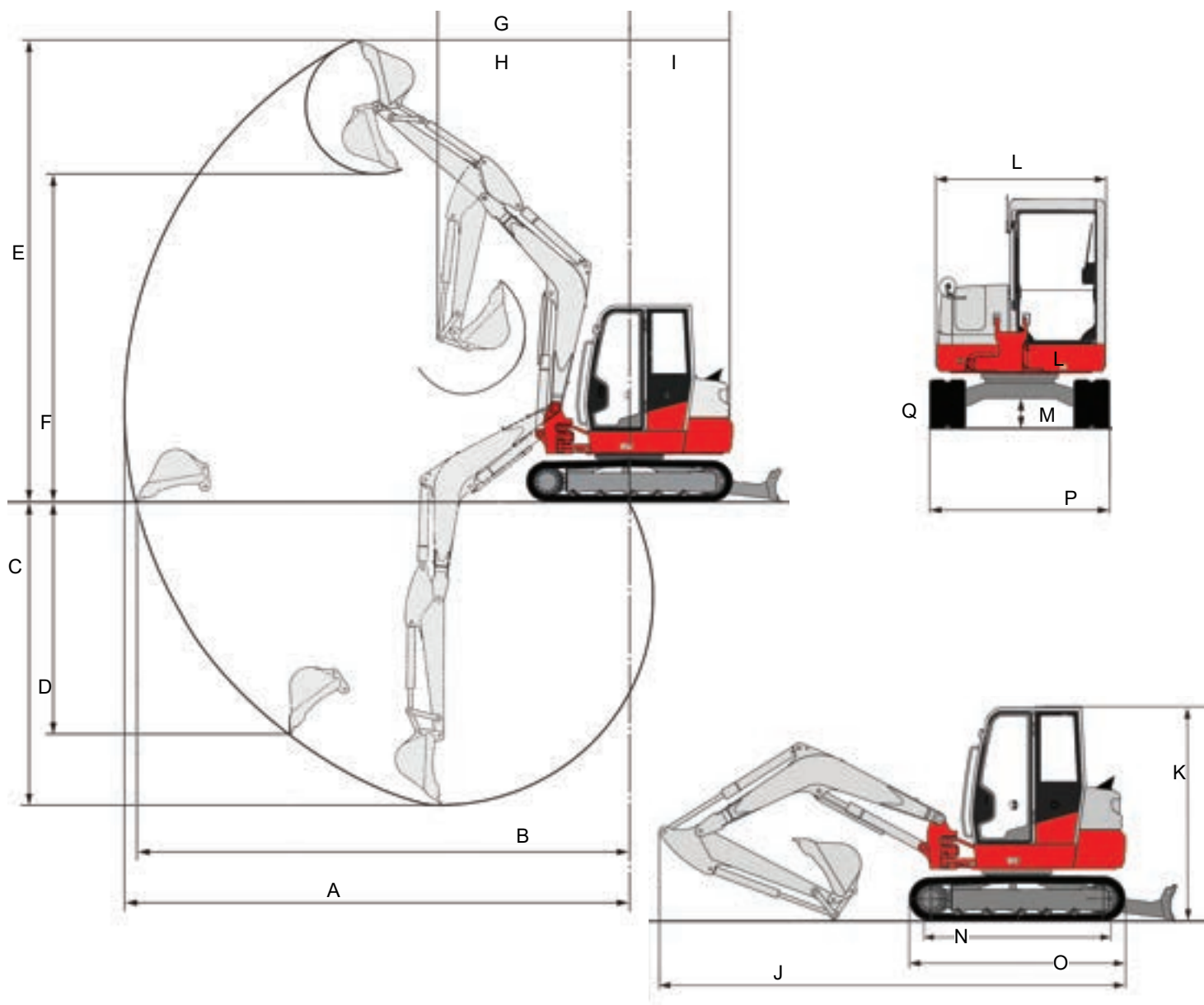

MACHINE DIMENSIONS	1,620 mm ARM	1,780 mm ARM
A Maximum Reach	6,120 mm	6,270 mm
B Maximum Reach at Ground Level	5,975 mm	6,130 mm
C Maximum Digging Depth	3,735 mm	3,895 mm
D Maximum Vertical Digging Depth	2,830 mm	2,980 mm
E Maximum Height of Cutting Edge	5,835 mm	5,940 mm
F Maximum Dumping Height	4,115 mm	4,220 mm
G Front Swing Radius	2,390 mm	2,420 mm
H Front Swing Radius with Boom Offset	1,945 mm	1,975 mm
I Slew Radius		1,300 mm
J Overall Length	5,540 mm	5,550 mm
K Overall Height (Cab / Canopy)		2,560 mm / 2,575 mm
L Upper Structure Overall Width		1,870 mm
M Ground Clearance		330 mm
N Crawler Base		2,050 mm
O Crawler Overall Length		2,575 mm
P Crawler Overall Width		2,000 mm
Q Crawler Shoe Width		400 mm



© 2019 Takeuchi MFG. Co., Ltd. All Rights Reserved. In accordance with our established policy of continued improvement, specifications and features are subject to change without notice. Pictures may show options other than standard equipment.

FORM: TB260 Compact Excavator Spec Sheet - Mar. 2019

TAKEUCHI™
From World First to World Leader