

nifty

Heightrider

Operating & Safety Instructions

**MODEL HR12 (SP34)
& HR12 4x4 (SP34 4x4) SERIES**

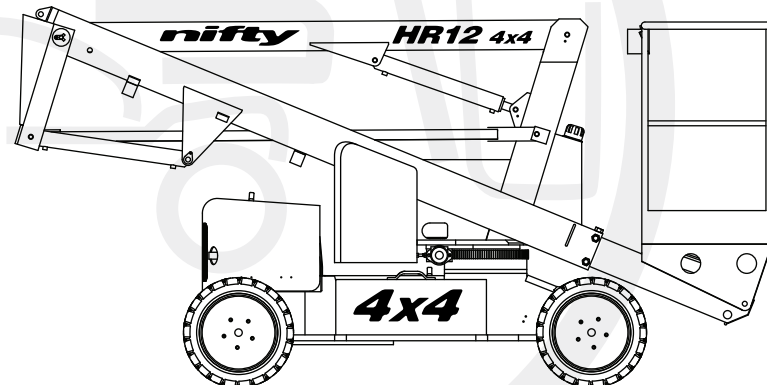
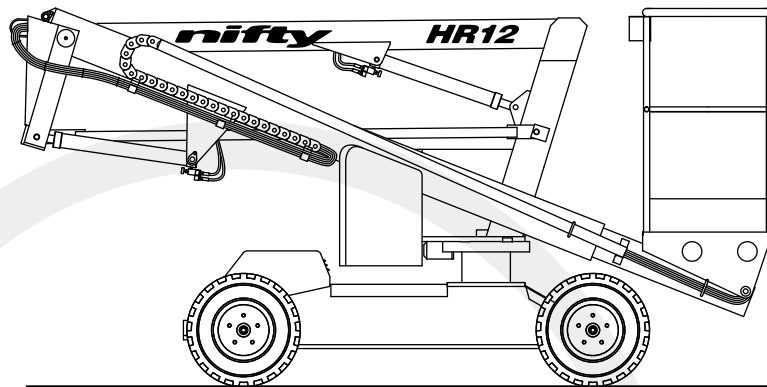

Manufactured by:
Niftylift Limited
Chalkdell Drive
Shenley Wood
Milton Keynes
MK5 6GF
England

www.niftylift.com
e-mail: info@niftylift.com
Tel: +44 (0)1908 223456
Fax: +44 (0)1908 312733



niftylift.com
info@niftylift.com

M50192/16



Table of Contents

1	INTRODUCTION AND GENERAL INFORMATION	PAGE
1.1	Foreword	2
1.2	Scope	3
1.3	Introducing the “Height Rider” Self Propelled (SP) Series	3
1.4	General Specification	4
1.5	Identification	5
1.6	EC Declaration of Conformity	6
2	SAFETY	
2.1	Mandatory Precautions	7-10
2.2	Environmental Limitations	10
2.3	Noise & Vibration	11
2.4	Test Report	11
3	PREPARATION AND INSPECTION	
3.1	Unpacking	12
3.2	Preparation for Use	12
3.3	Pre-Operational Safety Check Schedules	13-14
3.4	Placard, Decals and Installation	15-17
3.5	Torque Requirements	18
4	OPERATION	
4.1	Control Circuit Components	19-21
4.2	Ground Control Operation	22-23
4.3	Platform Control Operation	24-26
4.4	Drive Control Operation	27
4.5	Cage Weigh System	28
4.6	Batteries and Charging	29-30
4.7	Transporting, Towing, Craneage, Storage and Setting to Work	31-34
5	EMERGENCY CONTROLS	
5.1	General	35
5.2	Emergency Procedures - Incapacitated Operator	35
5.3	Emergency Procedures - Machine Failure	35
5.4	Incident Notification	35
6	RESPONSIBILITIES	
6.1	Changes in Ownership	36
6.2	Inspection/ Service Check List	37-38
APPENDIX A		
	Safety Related Parts of the Control System (SRP/CS)	39

1 Introduction and General Information

1.1 FOREWORD

The purpose of these manuals is to provide the customer with appropriate safety operating and maintenance instructions essential for proper machine operation.

All information in these manuals should be **READ** and fully **UNDERSTOOD** before any attempt is made to operate the machine. **THESE MANUALS ARE VERY IMPORTANT TOOLS** - Keep them with the machine at all times.

The manufacturer has no direct control over machine application and use, therefore conformance with good safety practices is the responsibility of the user and his operating personnel.

All information in these manuals is based on the use of the machine under proper operating conditions. Alteration and/or modification of the machine are strictly forbidden.

One of the most important facts to remember is that any equipment is only as safe as those who operate it.

DANGER, WARNING, CAUTION, IMPORTANT, INSTRUCTIONS AND NOTICE

Any place these topics may appear, either in this manual or on the machine, they are defined as follows:

DANGER: If not correctly followed there is a high probability of serious injury or death to personnel.

WARNING OR CAUTION: If not correctly followed there is some possibility of serious injury or death to personnel.



THE '**SAFETY ALERT**' SYMBOL IS USED TO CALL ATTENTION TO POTENTIAL HAZARDS THAT MAY LEAD TO SERIOUS INJURY OR DEATH, IF IGNORED.

IMPORTANT AND INSTRUCTIONS: Denotes procedures essential to safe operation and prevention of damage to or destruction of the machine.

NOTICE: Indicates general safety rules and/or procedures relating to the machine.

It is the owner's/user's responsibility to know and comply with all applicable rules, regulations, laws, codes and any other requirements applicable to the safe use of this equipment.

1.2 SCOPE

These operating instructions contain all the necessary information required to allow the safe operation of any Niftylift Height Rider HR12 powered by electric (DC), diesel (D), petrol/gasoline (P) engine, or a combination of these.

For further technical information, circuit diagrams and specific instructions for all maintenance which may need to be carried out by specialist trained personnel, see the associated Workshop and Parts manual for your model of Niftylift Height Rider.

1.3 INTRODUCING THE HEIGHT RIDER SELF-PROPELLED (SP) SERIES

Please note at the time of going to press all information, illustrations, details and descriptions contained herein are valid. Niftylift reserves the right to change, modify or improve its products without any obligations to install them on previously manufactured machines.

If you require further information after reading this manual, please do not hesitate to contact us.

Niftylift Ltd, Chalkdell Drive, Shenley Wood, Milton Keynes MK5 6GF, UK

Tel: +44 (0) 1908 223456 Fax: +44 (0) 1908 312733

Niftylift Inc, 1525 S. Buncombe Road, Greer, SC 29651 USA

Tel: +01 864 968 8881 Fax: +01 864 968 8836

Nifty Pty Ltd, 11 Kennington Drive, Tomago, NSW 2322, Australia

Tel: +61 (0) 2 4964 9765 Fax: +61 (0) 2 4964 9714

Driven from the platform, the Niftylift Height Rider is an extremely versatile articulated boom platform of unique and simple design. It is capable of placing two men and their tools up to a height of 12.20m (40ft) or an outreach of 6.10m (20ft 1in).

The booms are mounted via a 360° powered swing mechanism onto a compact narrow base with a tight turning circle that ensures excellent manoeuvrability and maximum efficiency.

High traction tyres and powerful hydraulic wheel motors give unsurpassed performance with the option of fast drive speed when the booms are in the stowed position. Automatic braking and audible alarms activated by a tilt sensor help to prevent the operator from working on unsafe terrain whilst elevated.

A simple, all-hydraulic proportional control system gives smooth, reliable movement of the platform and maximum reliability in the harshest environments.

Models include the following:

E: - DC ELECTRIC

D: - DIESEL

P: - PETROL

A: - AIR

BE: - BI-ENERGY (DIESEL & BATTERY)

PE: - PETROL & BATTERY

PG: - PETROL & LPG (PROPANE)

T: - TRI - ENERGY (PETROL, PROPANE & BATTERY)

nifty Height Rider/SP Series

Operating & Safety Instructions

1.4 GENERAL SPECIFICATION

FEATURE	HR12N	HR12 4x4
MAXIMUM HEIGHT - WORKING	12.20m 40ft	12.25m 40ft 2in
MAXIMUM HEIGHT - PLATFORM	10.20m 33ft 6in	10.25m 33ft 8in
MAXIMUM OUTREACH	6.10m 20ft 6in	
MAXIMUM HEIGHT – STOWED	1.90m 6ft 3in	1.94m 6ft 4in
MAXIMUM WIDTH	1.50m 4ft 11in	1.62m 5ft 4in
MAXIMUM LENGTH – STOWED	4.10m 13ft 5in	3.98m 13ft 1in
PLATFORM CAPACITY	200kg 440lbs	
WHEELBASE	1.90m 6ft 3in	
TURNING RADIUS – OUTSIDE	3.15m 10ft 6in	3.4m 11ft 2in
TURRET ROTATION	355°	
TURRET TAILSWING	Zero	
TRAVEL SPEED – STOWED	0 - 2.1mph 0 - 3.4kph	0 - 2.3mph 0 - 3.7kph
PLATFORM SIZE	0.65m x 1.10m 25in x 44in	
CONTROLS	Fully Proportional Hydraulic	
HYDRAULIC PRESSURE	200bar	
TYRES	Foam Filled	
GRADEABILITY	25%	30%
GROUND CLEARANCE	185mm 7.25in	260mm 10.24in
MINIMUM VEHICLE WEIGHT	3435kg 7573lbs	3470kg 7650lbs
MAXIMUM GROUND PRESSURE	0.056kN/cm ² 11700lb/ft ²	0.043kN/cm ² 8980lb/ft ²
MAXIMUM ALLOWABLE INCLINATION	3.0°	4.0°
POWER SOURCE	E (Electric) models - 8 x 6v 250 AH batteries P (G) (Petrol/Gasoline) models - Honda GX240 Engine D (Diesel) models - Kubota OC60 or OC95 engine (D722 - 4x4 Version)	

1.5 IDENTIFICATION (UK PLATE)

			
NIFTYLIFT LTD. RINGLE DRIVE, STONEBRIDGE MILTON KEYNES MK13 0ER ENGLAND TEL 01908 223456 : FAX 01908 312733 e-mail : info@niftylift.com			
SERIAL No			
TYPE			
YEAR OF MANUFACTURE			
WEIGHT			kg
RATED LOAD	PERSONS	+	kg
MAXIMUM SAFE WORKING LOAD			kg
MAXIMUM PULL			N
MAXIMUM WIND SPEED			m/s
MAX. ALLOWABLE INCLINATION			Deg.
MAXIMUM HYDRAULIC PRESSURE			bar
MAXIMUM VOLTAGE			V
AMPS			A
ELEC. CCT D	ISSUE		
HYD. CCT D	ISSUE		
			P10205

This manufacturer's plate is attached to Boom 1 on each machine at the time of manufacture on every Niftylift. Please ensure all sections have been stamped and are legible.

1.6 EC DECLARATION OF CONFORMITY (Typical)



EC DECLARATION OF CONFORMITY

MANUFACTURER
AND PERSON
RESPONSIBLE FOR
DOCUMENTATION:

NIFTYLIFT LTD
MARTIN CROSS

ADDRESS:

CHALKDELL DRIVE,
SHENLEY WOOD,
MILTON KEYNES,
MK5 6GF,
ENGLAND.

MACHINE TYPE:

MOBILE ELEVATING WORK PLATFORM

MODEL TYPE:

SERIAL NUMBER:

** /*****

APPROVED BY:

NIFTYLIFT LTD
CHALKDELL DRIVE,
SHENLEY WOOD,
MILTON KEYNES,
MK5 6GF,
ENGLAND.

TECHNICAL FILE NUMBER:

APPLICABLE STANDARDS:

EN 280:2013
DIN EN 60204-1, 2006/42/EC

We hereby declare that the above mentioned machine conforms with the requirements of the Machinery Directive, 2006/42/EC and EMC Directive 2004/108/EC.

SIGNED:

DATE: 19/10/2015

NAME: Steven Redding

POSITION: Development Director

NOTE:

THIS DECLARATION CONFORMS WITH THE REQUIREMENTS OF ANNEX II-1.A OF THE COUNCIL DIRECTIVE 2006/42/EC ANY MODIFICATIONS TO THE ABOVE MENTIONED MACHINE WILL INVALIDATE THIS DECLARATION, AND THE MACHINE'S APPROVAL.

2 Safety

2.1 MANDATORY PRECAUTIONS

When operating your Niftylift, your safety, physical and psychological well-being is of utmost concern. In order to fully appreciate all aspects of the machine's operation it should be ensured that each operator has **READ** and fully **UNDERSTOOD** the relevant manual covering machine use, maintenance and servicing. If any doubts exist concerning any points covered in your manual, contact your local dealer or Niftylift Ltd.

Before using any Niftylift, thoroughly inspect the machine for damage or deformation to all major components. Likewise, check the control systems for hydraulic leaks, damaged hoses, cable faults or loose covers to electrical components. At no time should damaged or faulty equipment be used - Correct all defects before putting the platform to work. If in doubt, contact your local dealer or Niftylift Ltd (see Section 1.3 for contact details).



THE MANUFACTURER HAS NO DIRECT CONTROL OVER THE MACHINE APPLICATION AND USE. THEREFORE CONFORMATION WITH GOOD SAFETY PRACTICES IS THE RESPONSIBILITY OF THE USER AND HIS OPERATING PERSONNEL. FAILURE TO UNDERSTAND AND FOLLOW ALL SAFETY RULES COULD RESULT IN SERIOUS INJURY OR DEATH.

- 2.1.1** Only trained persons will be permitted to operate the Niftylift.
- 2.1.2** Always operate the Niftylift in full accordance with the manufacturer's Operating & Safety Instructions for that model.
- 2.1.3** Before use each day and at the beginning of each shift the Niftylift shall be given a visual inspection and functional test including, but not limited to, operating and emergency controls, safety devices, personal protective clothing, including fall protection, air, hydraulic and fuel system leaks, cables and wiring harness, loose or missing parts, tyres and wheels, placards, warnings, control markings and Operating and Safety Manuals, guards and guard rail systems and all other items specified by the manufacturer.
- 2.1.4** Any problems or malfunctions that affect operational safety must be repaired prior to use of the platform, with specific regard to any safety components refer to the Parts Manual for part numbers and details. If in doubt, contact Niftylift Ltd (Details on page 3). **Ensure wheels are chocked before carrying out any maintenance that involves brake release as described in Section 4.7.2 – Towing.**
- 2.1.5** Always ensure that all warning labels, instructions, placards, control markings and Safety Manuals are intact and clearly legible. If replacements are required contact your local dealer or Niftylift. Always observe and obey safety and operating instructions on such labels.
- 2.1.6** Do not alter, modify or disable in any way the controls, safety devices, interlocks or any other part of the machine.
- 2.1.7** Before the Niftylift is used and during use the user shall check the area in which it is to be used for possible hazards such as, but not limited to, uneven ground drop-offs, holes, bumps, obstructions, debris, floor and overhead obstructions, high voltage conductors, wind and weather, unauthorised persons and any other possibly hazardous conditions.

nifty Height Rider/SP Series

Operating & Safety Instructions

2.1.8 Never exceed the maximum platform capacity, as indicated on the decals and machine serial plate.

2.1.9 Only operate the Niftylift on a firm, level surface.

2.1.10 Never position any part of the Niftylift inside the **Minimum approach distances (MAD)** to above-ground electrical conductors as listed in the table below. (Reference ISO 18893:2014).

Voltage range (kV)	MAD (m)
<0.7	1
≥0.7 to 7	1.2
>7 to 50	3
>50 to 220	4
>220 to 500	5
>500 to 750	10
>750 to 1000	13
>1000 to 1250	16



THIS MACHINE IS NOT INSULATED.

If in doubt, contact the local appropriate governing authority.

2.1.11 On entering the platform, ensure that the drop down entry bar is closed afterwards.

2.1.12 Use of an approved safety belt and lanyard, hard hat and appropriate safety clothing is mandatory. Fasten harness to designated harness securing points within the platform and do not remove until leaving the platform whilst in the stowed position.

2.1.13 Always remain standing within the platform. Do not attempt to increase your height or reach by standing and/or climbing on the platform guard rails or any other object. **KEEP YOUR FEET ON THE PLATFORM FLOOR.** Do not sit, stand or climb on the guard rail, mid rail or boom linkage. Use of planks, ladders or any other devices on the Niftylift for achieving additional height or reach shall be prohibited.



2.1.14 Do not use the platform levelling system to artificially increase the outreach of the platform. Never use boards or ladders in the platform to achieve the same result.

2.1.15 Do not use the platform to lift overhanging or bulky items that may exceed the maximum capacity or carry objects that may increase the wind loading on the platform. (e.g. Notice boards etc.)

2.1.16 The Niftylift shall not be operated from a position on trucks, trailers, railway cars, floating vessels, scaffolds or similar equipment unless the application is approved in writing by Niftylift Ltd in the UK.

2.1.17 Always check that the area below and around the platform is clear of personnel and obstructions before lowering or slewing. Care should be taken when slewing out into areas where there may be passing traffic. Use barriers to control traffic flow or prevent access to the machine.

Important:- To prevent damage to the cage step, it is necessary to elevate the booms a minimum of **250mm** (10 in) from their stowed position **before** slewing. Also, when lowering the booms down to their stowed height, check that the cage step is not directly above any wheel to prevent damage to the step, similarly check that the booms are clear of the front canopy to prevent damage.

- 2.1.18** Stunt driving and horseplay, on or around the Niftylift, shall not be permitted.
- 2.1.19** When other moving equipment and vehicles are present, special precautions shall be taken to comply with local ordinances or safety standards established for the work place. Warnings such as, but not limited to, flags, roped off areas, flashing lights and barricades shall be used.
- 2.1.20** Before and during driving while the platform is elevated the operator shall maintain a clear view of the path of travel, maintain a safe distance from obstacles, debris, drop offs, holes, depressions, ramps and other hazards to ensure safe elevated travel. Maintain a safe distance from overhead obstacles.
- 2.1.21** Under all travel conditions the operator shall limit travel speed according to conditions of ground surface, congestion, visibility, slope, location of personnel and other factors causing hazards of collision or injury to personnel.
- 2.1.22** The aerial platform shall not be driven on grades, side slopes or ramps exceeding those for which the aerial platform is rated by the manufacturer.
- 2.1.23** The aerial platform is not equipped for or intended for use on a public highway.
- 2.1.24** It shall be the responsibility of the user to determine the hazard classification of any particular atmosphere or location. Aerial platforms operated in hazardous locations shall be approved and suitable for the duty. (See ANSI/NFPA 505 where applicable).
- 2.1.25** The operator shall immediately report to his supervisor any potentially hazardous location(s) (environment) which become evident during operation.
- 2.1.26** If an operator encounters any suspected malfunction of the Niftylift or any hazard or potentially unsafe condition relating to capacity, intended use or safe operation, he shall cease operation of the Niftylift and request further information as to safe operation from his management, or owner, dealer or manufacturer before further operation of the Niftylift.
- 2.1.27** The operator shall immediately report to his superior any problems or malfunctions of the Niftylift, which becomes evident during operation. Any problems or malfunctions that affect the safety of operation shall be repaired prior to continued use.
- 2.1.28** The boom and platform of the Niftylift shall not be used to jack the wheels off the ground.
- 2.1.29** The Niftylift shall not be used as a crane.
- 2.1.30** The Niftylift shall not be positioned against another object to steady the platform.
- 2.1.31** Care should be taken to prevent rope, electric cords and hoses from becoming entangled in the aerial platform.
- 2.1.32** Batteries shall be recharged in a well-ventilated area free of flame, sparks or other hazards, (e.g. do not smoke near the machine) which may cause explosion. Highly explosive hydrogen gas is produced during the charging process.
- 2.1.33** When checking electrolyte levels great care should be taken to protect eyes, skin and clothing. Battery acid is highly corrosive and protective glasses and clothing is recommended.

nifty Height Rider/SP Series

Operating & Safety Instructions

2.1.34 If the platform or elevating assembly becomes caught, snagged or otherwise prevented from normal motion by adjacent structure or other obstacles, such that control reversal does not free the platform, all personnel shall be removed from the platform safely before attempts are made to free the platform using ground controls.

2.1.35



When the machine is not in use always stow the booms correctly. **NEVER LEAVE THE KEYS IN THE MACHINE**, if it is to be left for any period of time. Use wheel chocks if leaving on an incline.

2.1.36

The engine must be shut down while fuel tanks are being filled. Fuelling must be done in a well-ventilated area free of flame, sparks or any other hazard that may cause fire or explosion. **PETROL (GASOLINE), LIQUID PROPANE AND DIESEL FUELS ARE FLAMMABLE.**

2.1.37



NEVER START THE NIFTYLIFT IF YOU SMELL (PETROL) GASOLINE, LIQUID PROPANE OR DIESEL FUEL. THESE FUELS ARE HIGHLY FLAMMABLE

2.1.38

The operator must ensure that engine powered machines are used in a well-ventilated area to minimise the risk of carbon monoxide poisoning.

2.1.39

The operator shall implement means provided to protect against use by unauthorised persons.

2.1.40

Never remove anything that may affect the stability of the machine such as, but not limited to, batteries, covers, engines, tyres or ballast.

2.1.41

The operator must ensure that the controls are not obstructed (e.g. by tools or equipment) and **clear access to the Emergency Stop** is available at all times.

2.1.42

All persons in the cage must take suitable precautions to prevent items falling or being ejected from the cage. E.g. Tethering tools to the machine or operator if practical and an assessment of any resulting risks is acceptable.

2.2 ENVIRONMENTAL LIMITATIONS

All "Niftylift" Height Riders are limited to operation as previously described, not suitable for rough terrain work. Unless specifically configured otherwise, the machine will have short time rating for operation in extreme temperatures. i.e. Reduced battery cycle times for low temperatures, e.g. freezers, food storage etc., cooling limitations for high temperatures. i.e. oil temperature not to exceed -23 to 90° Celsius.

The recommended operational range for these machines is - 5°C to +40°C. Please contact Niftylift Ltd for special considerations if the machine is required to operate outside these temperatures.

Extended operation in dusty environments is not recommended, frequent cleaning will be necessary. All dust, dirt, salt encrustation, excess oil or grease should be removed. Deposits of paint or bitumen, particularly on legends or labels should be removed.

All standard Niftylift machines are rated for a wind speed of 12.5 m/s, which equates to 45kph / 28mph or force 6 on the Beaufort scale. No attempt should be made to operate a Niftylift in wind strengths above this limit and if the operator has any doubts over the wind speed he /she should cease operation immediately until it can be established that the wind speed has fallen to a safe level.



DO NOT USE THE NIFTYLIFT IN ELECTRICAL STORMS

2.3 NOISE AND VIBRATION

The airborne noise emission on the Height Rider range of machines does not exceed 85dB(A), measured at a perpendicular distance of 4m, under equivalent continuous A-weighted sound pressure test conditions. This was based on a Diesel powered machine, working on high throttle, and under load. All other models will exhibit significantly lower emissions than this figure, dependant on power option. In normal operation the Vibration level to which the operator is subjected will not exceed a weighted root mean square acceleration value of 2.5 m/s².

2.4 TEST REPORT

All Niftylift machine models are subjected to a comprehensive 'type test' which duplicates all combinations of safe working load (SWL), overload, windage, inertia and pull force to assess the various safe stability criteria. Self propelled machines are also subjected to kerb and braking tests at the SWL to satisfy additional 'worse case' stability requirements.

Each individual machine is then subjected to static overload tests on flat level ground with 150% of the SWL, exceeding the requirements of EN280 for power operated MEWPs. Self propelled machines are also tested at the maximum working angle **plus** 0.5° with a test load of 125% of the SWL. Finally, on all machines, a functional test is performed with 110% of SWL.

All safety devices are checked for correct operation, operating speeds are checked against benchmark figures and the dynamic functions ensure that all acceleration and deceleration forces are within acceptable limits. All noted defects are rectified and recorded before the machine is permitted to enter into service.

Operating & Safety Instructions

3 Preparation and Inspection

3.1 UNPACKING

Since the manufacturer has no direct control over the shipping or carriage of any Niftylift it is the responsibility of the dealer and/or owner and/or leaser to ensure the Niftylift has not been damaged in transit and a Pre-operational Report has been carried out by a qualified engineer before the aerial platform is put into service.

- A) Remove all ropes, straps and or chains used to secure the aerial platform during transit.
- B) Ensure any ramp, loading dock or forklift used is capable of supporting or lifting the aerial platform.
- C) If the aerial platform is to be driven, please ensure that the operator has read and fully understood this entire manual. Refer to the appropriate section for precise operating instructions.

*****Carry out the Pre-operational Report before placing machine in service.**

3.2 PREPARATION FOR USE

Whilst every effort has been made at the Niftylift factory to ensure your machine arrives in a safe and operable condition it is necessary to carry out a systematic inspection prior to putting the aerial platform into service.



THIS IS NOT A REQUEST IT IS MANDATORY

To assist the user in this task you will find enclosed a Pre-operational Report, which must be filled out upon delivery/receipt of the machine.

Before the user carries out the Pre-operational Report he must have read and fully understood all the contents of the Operating, Safety and Maintenance Manual.



WARNING - DO NOT OPERATE A POTENTIALLY DEFECTIVE OR MALFUNCTIONING MACHINE. CORRECT AND REPAIR ANY DEFECTS BEFORE OPERATING YOUR NIFTYLIFT.

3.3 PRE-OPERATIONAL SAFETY CHECK SCHEDULES

Before use each day and at the beginning of each shift the aerial platform shall be given a visual inspection and functional test including, but not limited to, the following:

3.3.1 DAILY SAFETY CHECKS

- 1) Check that all labels (decals) are in place and legible.
- 2) Visually inspect the machine for damaged or loose components.
- 3) Check that batteries are charged (i.e. Charger has a solid green light and a pulsing red light).
- 4) Check the fuel level (if applicable).
- 5) Check that canopies/covers and guards are in place and secure.
- 6) Check that the boom rest switch is operable (if applicable).
- 7) Check that control levers are secure and operate freely.
- 8) Check that operating buttons and emergency stop buttons function correctly.
- 9) Check the operation of the manual hand pump.
- 10) Visually inspect all hydraulic hoses and fittings for damage or leaks.
- 11) Check that the platform pivot pins and their tag bolts are secure.
- 12) Check that the tilt alarm is functioning correctly (On a slope of 3° or more the alarm should sound and drive should be disabled).
- 13) Check the operation of the cage weigh system (If fitted).
- 14) Check the operation of the SiOPS safety bar (See Section 4.3.3). SiOPS should halt operation of the machine when activated. **Do not use a machine that continues to operate over this safety device.** Report any malfunctions and remove the machine from service until repaired.

3.3.2 WEEKLY SAFETY CHECKS

- 1) Inspect tyres and wheels for damage and wear.
- 2) Check that the joystick manipulators are secure.
- 3) Check battery fluid levels and specific gravity (after charging) and general condition.
- 4) Check hydraulic oil level, ISO Grade 22 (European), Grade 32 (Rest of World).
- 5) Inspect the engine air filter and clean or replace if necessary.
- 6) Inspect hose track for damage or missing parts.

Operating & Safety Instructions

3.3.3 MONTHLY SAFETY CHECKS

- 1) Check the engine oil level (if applicable).
- 2) Check the wheel nuts (torque 65ft lbs / 86Nm).
- 3) Check that the bolts holding the wheel motors to the chassis are secure.
- 4) Check that the slew worm is secured and correctly in mesh. Clean and re-grease.
- 5) Inspect brakes for operation and wear.
- 6) Grease the knuckle and centre post.
- 7) Inspect the engine fuel tank for damage or leaks.
- 8) Check telescopic boom wear pads and nylon studs (if applicable).
- 9) Check that the end cap on the main knuckle pin is secure and the roll pin is in place.
- 10) Check and adjust if necessary the Nylatron studs around the telescope boom.
- 11) Every **three** months check and verify the calibration of the cage weigh system.
- 12) Every **Six** months perform a **thorough examination** in accordance with the 'Lifting Operation and Lifting Equipment Regulations' (LOLER) 1998, Regulation (9)(3)(a).

3.3.4 ANNUAL SAFETY CHECKS

- 1) Check that all pivot pins and their tag bolts are secure.
- 2) Inspect for any cracks or badly rusted areas on booms and chassis.
- 3) Change the hydraulic oil filters.
- 4) Check the bushes in the front wheel hubs for wear.
- 5) Check that slew ring bolts are secure (torque 206ft lbs. 279Nm).

3.4 PLACARD, DECALS & INSTALLATION (UK SPEC)

ITEM	DESCRIPTION	NUMBER	QTY	
1	SWL 200kg	P14801	1	
2	Harness Point	P14883	2	
4	General Notice	P18870	1	
5	Blank Serial Plate	P15383	1	
6	Daily Safety Check List	P14908	1	
7	Trip – Push to Reset	P19056	1	
8	Travel Direction	P14784	2	
9	If Alarm Sounds...	P14868	2	
10	E-Stop, Do Not Disable	P14864	2	
11	Head Protection	P14921	1	
12	Manual Hand Pump	P19716	1	
13	Are you trained?	P22055	1	
14	“Nifty HR12” – Grey	P14604	2	
15	“Niftylift.com” – Black	P14390	1	
16	“Height Rider 12” – Grey	P14605	1	
17	General Warning	P21970	2	
18	Booms / Brakes Selector	P19446	1	
19	Foam Filled Tyres	P14932	1	
20	Drive Wheel Lock	P19444	1	
21	Base/Cage selector	P19445	1	
22	No Step	P14785	1	
23	Cage Levelling	P10853	1	
25	Point Load	16.7kN (2x4)	P20607	4
		21.2kN (Narrow)	P27687	4
		20.8kN (4x4)	P20634	4
26	Battery Management	P11777	1	
27	General Crush	P14782	3	
28	Battery Isolator	P18610	1	
29	Battery Charger	P14904	1	
31	Diesel	P14414	1	
33	Hydraulic Levers - Cage	P14939	1	
34	Hydraulic Levers - Base	P14937	1	
35	Cage Gate Warning	P18432	1	
36	Cage Controls	P18961	1	
38	Base Controls	P21055	1	
39	Noise Warning	P17124	1	
40	Operators Manual	P14892	1	
41	Overload Warning	P18848	2	
43	Trip – Push to Reset	P19056	1	

nifty Height Rider/SP Series

Operating & Safety Instructions

45	Cage tie-down warning	P21404	2
46	No Step	P14785	2
47	Footswitch	P14884	1
48	Logo - 4x4	P14697	2
49	Battery isolator (4x4)	P18600	1
50	Brake Release (4x4)	P18788	1
51	Power to cage socket	P24787	1
52	Charger Socket	P19699	1
53	Emergency Controls	P21700	1

nifty

HR12 Series

nifty Height Rider/SP Series Operating & Safety Instructions

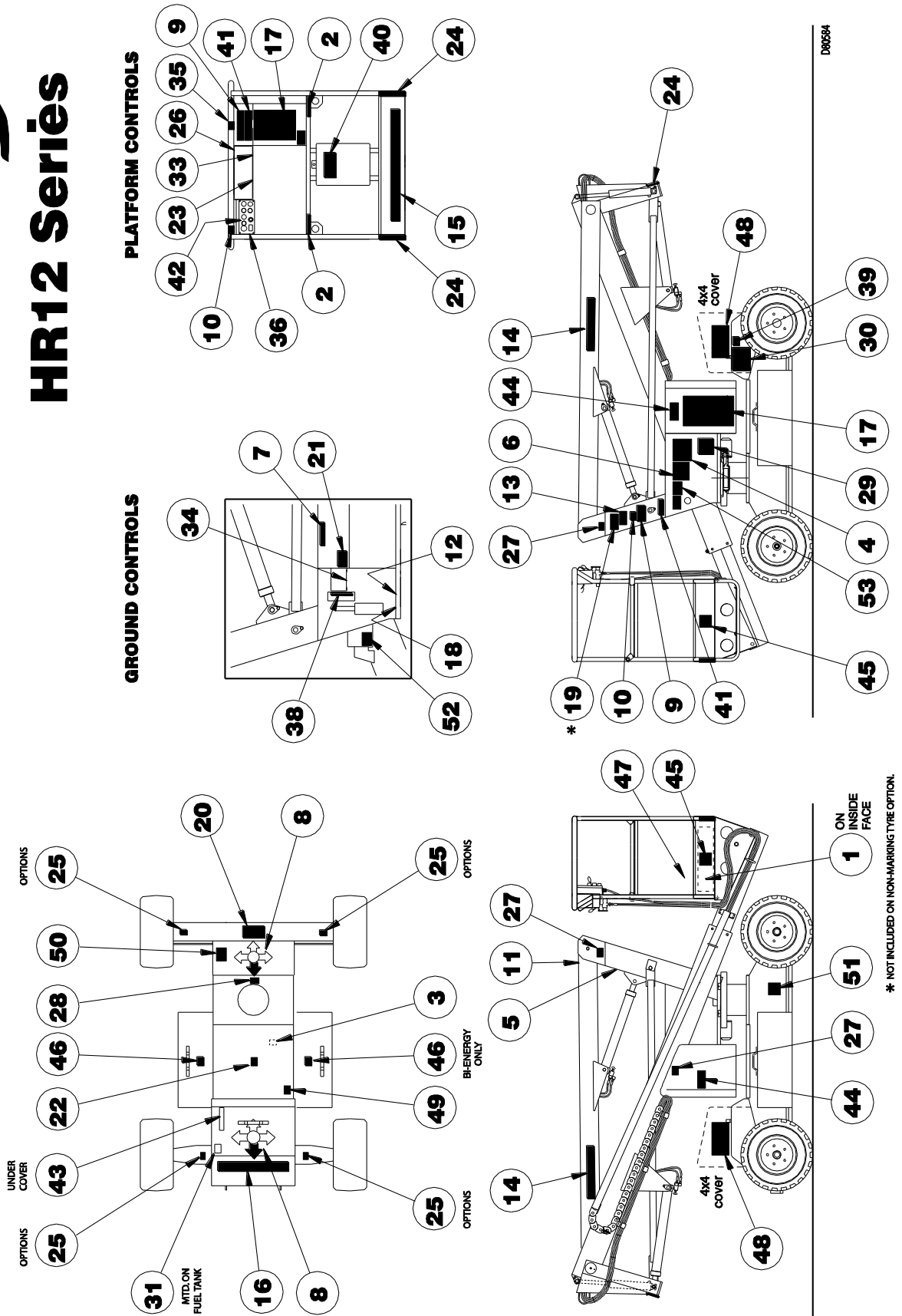

D06584

Operating & Safety Instructions**3.5 TORQUE REQUIREMENTS**

BOLT QUALITY/SIZE	Tightening torque in lbs ft (Nm)					
	Plated			Unplated		
Grade	8.8	10.9	12.9	8.8	10.9	12.9
M 6	5 (7)	8 (10)	9 (12)	6 (8)	8 (11)	10 (13)
M 8	13 (17)	18 (25)	22 (29)	14 (19)	20 (27)	23 (32)
M 10	25 (34)	36 (49)	43 (58)	27 (37)	40 (54)	46 (63)
M 12	43 (58)	63 (85)	73 (99)	47 (63)	69 (93)	80 (108)
M 14	68 (93)	100 (135)	117 (158)	74 (101)	109 (148)	127 (172)
M 16	106 (143)	154 (209)	180 (245)	115 (156)	168 (228)	197 (267)
M 20	212 (288)	301 (408)	352 (477)	224 (304)	328 (445)	384 (521)
M24	362 (491)	515 (698)	602 (806)	383 (519)	561 (760)	656 (889)
WHEEL NUTS	65ft lbs (86 Nm)					
SLEW RING BOLTS	206ft lbs (279 Nm)					

This torque chart is based on the following assumptions:

- 1) Bolts to ISO 898-1 "Mechanical properties of fasteners made of carbon steel and alloy steel"
- 2) For "unplated" bolts, all grades:
 - Hex head bolts
 - Black oxide steel bolt with a rolled & oiled thread, no finish on steel nut
 - Prevailing torque includes Nylock (minimum prevailing torque figure assumed)
 - Medium Clearance holes to ISO 273
 - Bolt tightening condition = Yield factor of 75%
- 3) For "plated" bolts, all grades:
 - Hex head bolts
 - Zinc plated oiled (rolled or cut) steel external thread with no finish on steel internal thread
 - Prevailing torque includes Nylock (minimum prevailing torque figure assumed)
 - Medium Clearance holes to ISO 273
 - Bolt tightening condition = Yield factor of 75%

Figures quoted in **Nm** have been calculated in Nm and then rounded to the nearest whole number. Figures quoted in **lb-ft** have been calculated in Nm, converted using a factor of 0.737561 and then rounded.

4 Operation

4.1 CONTROL CIRCUIT COMPONENTS

- 4.1.1 CONTROL BOARD:** - Situated under the rear cover, the encapsulated control board comprises a PCB. (Printed circuit board) that incorporates all of the relays to control the machines operation. The control board is common to all models, and contains functions, which might not be utilised on your particular machine. A thermal trip switch is integral to the box, which protects the control circuit and components. If power is lost, the switch can be manually reset.
- 4.1.2 TILT ALARM:** - Fitted to the top of the control board box, the tilt alarm is a solid-state sensor, which monitors the inclination of the machine. It directly controls the BRV (Brake Release Valve) and when the platform is in use, i.e. Booms are raised, if the inclination exceeds the pre-set limit, it will disable the drive to the machine and sound the alarm. In order to recover the machine, the platform operation is unaffected, allowing the operator to restore drive when the machine is stowed. It is then possible to drive back onto level ground, fully restoring machine operation.
- 4.1.3 SOUNDER:** - Situated beneath the PCB is a small electric sounder, which is used to provide an intermittent alarm whenever the machine is in operation. Pushing a green "power control" button or depressing the foot switch in the platform (if fitted) will energise this sounder. This serves to warn personnel of the operation of the machine.
- 4.1.4 KLAXON:** - Also mounted on the top of the control board box is a klaxon, which performs several functions: Firstly, it can be used as a manual alert, by pushing the "Horn" button at the platform control position. Secondly, it is this device, which sounds continuously if the tilt alarm sensor detects excessive inclination, with the booms raised. Lastly, it is linked into the battery management system, such that when low battery state is reached the "pulsing" of the DC motors is mimicked by the klaxon, re-enforcing the message to the operator to recharge the batteries.
- 4.1.5 DRIVE CONTROL VALVE (DCV):-** The motion control valve comprises several individual components all directly involved in the hydraulic supply to the wheel drive motors. Principal amongst these are the drive control valves, which electrically change the drive motor hydraulics supply from series flow to parallel, or vice versa. This control function is only available when the booms are lowered, and allows the operator to select "Hi" or "Lo" drive. "Hi" drive gives fast speed of travel, but low gradeability, "Lo" drive gives best gradeability, but slow speed. "Lo" drive is used for climbing inclines and delicate positioning of the machine.
- 4.1.6 BRAKE RELEASE VALVE (BRV):-** The motion control valve also incorporates a solenoid operated dump valve, which controls the brake function on the machine. This valve must be energised to allow the machine to move. If no voltage is present, the wheel motors will not be able to develop drive torque, whilst at the same time, the parking brakes will remain engaged. Only when a green "Power Control" push-button is being used (or the Platform Foot-switch is depressed) will the BRV operate. If the tilt alarm sensor detects an excessive inclination whilst the booms are raised it is the BRV which is de-energised to isolate the machine. (At the same time the klaxon tone changes to a continuous tone to indicate this condition).

Operating & Safety Instructions

- 4.1.7 BOOM SWITCH:** - Mounted on the end of the machine counterbalance, and operated by the upper boom, this switch controls both the operation of the tilt alarm sensor, and the speed control function. With the booms in the stowed position, the tilt alarm sensor is by-passed, allowing the machine to negotiate slopes in excess of the permissible working angle, without isolating the drive function. At the same time, "Hi" drive is possible, as is fast throttle on those machines so equipped. When the booms are raised, the tilt alarm sensor becomes activated, only slow speed operation is possible and only "Lo" drive is permitted. These control functions are of primary importance to safety of the machine and operator. Under no circumstances should this control function be isolated or by-passed. Note! On later machines the boom switch is located adjacent to the Knuckle, and works from a cam attached to Boom 3. This permits the operator to slightly raise the Booms whilst still permitting high-speed drive. All other functions remain the same.
- 4.1.8 BATTERY MANAGEMENT:** - Battery condition is permanently monitored by the control circuit, such that when available power has decreased to 20% of full charge, the battery status circuit begins to "chop" the power to the hydraulic power packs. This function causes the drive system to alternately stop and start, signalling to the operator that re-charging is necessary. At the same time the Klaxon will begin to sound intermittently re-enforcing the charge warning. At this point, sufficient power remains to drive to the nearest power point. Should the operator ignore the on-set of the discharge warning, the "chopping" will continue until the machine is rendered inoperative. Immediate charging will then be required.
- Under no circumstances should a machine be left fully discharged or severe battery damage can occur in a relatively short time.
- 4.1.9 BATTERY ISOLATORS:** - The battery-disconnect handles are located beneath the rear bonnet section and allow the machine control and power circuits to be isolated from the batteries. In order to isolate the batteries it is necessary to pull **both** release handles. The left side release handle also incorporates a control circuit connector. Pulling this handle also disconnects the supply to the PCB control box. Under normal operation, the machine key switch should be used to isolate the machine, with the battery isolator handles only being required for emergencies, in the event of a short circuit, or during routine maintenance.
- 4.1.10 DUTY SELECTOR:** - On multiple power option machines, one of the functions on the platform control station will be a duty selector. This key switch allows the selection of either power option, i.e. from Diesel to Battery or Petrol to battery, or vice-versa. On other machines this same key switch serves as an "On-Off" control.
- 4.1.11 DIESEL ENGINE:-** Generally a Kubota OC60, OC95 or D722 engine, driving a twin bodied pump with direct mounted pump dump valves (one per section), and integral relief valve on the rear pump. The arrangement allows two speed operation, fast throttle and automatic relief for ramp climbing.
- 4.1.12 DIESEL BOX:** - Located adjacent to the diesel engine, the diesel box combines all of the functions for dual power operation, (Bi-Energy machines), as well as controlling the diesel engine itself. The relays in this box control starting, high throttle, pump dump, duty selector and the diesel stop timer. There is also an integral thermal trip, which protects the throttle solenoid and other functions.

- 4.1.13 PETROL (GASOLINE) ENGINE:** - Generally a Honda GX 240 engine, driving a single body pump with direct mounted pump dump valve. The engine is also equipped with a throttle solenoid for two-speed operation.
- 4.1.14 PETROL (GASOLINE) BOX:** - Located adjacent to the petrol (gasoline) engine, the petrol (gasoline) box combines all of the functions for dual power operation, as well as controlling the petrol engine itself. The relays in this box control starting, high throttle, pump dump, duty selector and engine stop. here is also an integral thermal trip, which protects the throttle solenoid and other functions.
- 4.1.15 LPG OPERATION:**-On machines equipped for LPG operation (propane) the Honda engine will also have an LPG vaporiser, valve lock and micro-vac switch. The supply and regulation of the propane is governed by the installed gas bottle and regulator. The vapour take-off system requires a vaporiser to convert the liquid gas into an airborne mixture. This is then held by the micro-vac switch and valve lock until the engine turns over, creating a vacuum on the inlet to the engine carburettor. The micro-vac switch then tells the valve lock to open, admitting the gas to the engine. If the engine is halted, the system returns to normal, holding the gas until a re-start is attempted. When running on Petrol, the main tap to the gas bottle should be securely closed, to prevent the engine from trying to run on a mixture of the two fuels. If starting to run on LPG, it should be ensured that all petrol is discharged from the carburettor bowl before changing to LPG, since the engine will not run satisfactorily if any petrol is in the carburettor bowl. When turning on the gas, the bottle tap should be opened gradually so that the liquefied gas does not freeze up the vaporiser on contact. Warming up the engine on petrol first will ensure that the vaporiser is already hot enough to begin the gas conversion. A frozen vaporiser will not allow the machine to run on gas. Machines arranged for vapour take-off do not have a vaporiser, but still have the valve lock and micro-vac switch to control the flow of gas to the engine. The functions of the machine are as described above for the liquid take-off system.
- 4.1.16 CAGE WEIGH SYSTEM CONTROL BOARD :** - On machines equipped with the cage weigh system, the control printed circuit board is usually mounted in a box secured to the cage.
- 4.1.17 LOAD SENSING BAR (SIOPS™):** - This machine may incorporate a load sensing bar that senses if the operator has been pushed or has fallen against it. If the load applied to the front of the bar is greater than the pre-determined amount, the footswitch will be disabled to increase operator safety and reduce the possibility of sustained involuntary operation of the cage controls. For further information refer to Section 4.3.3.
- 4.1.18 ENGINE WATER TEMPERATURE:** - On those engines equipped with water-cooling, the high temperature sender is connected to an indicator light in the cage panel. High temperature will illuminate the indicator, but not shut down the engine. If the indicator light illuminates during operation, descend immediately and/or stop the engine.
- 4.1.19 ENGINE OIL PRESSURE:** - On those engines equipped with oil sensors, the low oil pressure sender is connected to an indicator light in the cage panel. Low oil pressure will illuminate the indicator, as would total loss of oil or the engine coming to a stop. If the indicator light illuminates during operation, descend immediately and/or stop the engine. When the cage key is turned to the 'engine' position, the light will illuminate to indicate that the engine is not running. This serves to remind the operator to turn the cage key switch 'Off' when not in use. Turning the key switch to 'Off' will de-energise any control relays that might eventually discharge the batteries.

Operating & Safety Instructions

4.2 GROUND CONTROL OPERATION

4.2.1 GROUND CONTROL STATION

ALWAYS ALLOW THE ENGINE TO WARM UP BEFORE OPERATING.



ALL MODELS

- 1) Ensure all red emergency stops are out.
- 2) Turn key switch at ground control station to ground (i.e. fully down).
- 3) Ensure function selector hand valve is turned to **Ground** position (i.e. fully down).
- 4) Turn duty selector in platform to **BATT** (battery) or **ENG** (engine).
- 5) If **BATT** (Battery) is selected go to step 9), if **ENG** (engine) is selected go to step 6).

DIESEL ENGINE OR BI-ENERGY MODELS

- 6) If **ENG** (engine) is selected go to step 7 for a **COLD ENGINE** or step 8 for a **WARM ENGINE**.
- 7) **COLD ENGINE:** - turn the main engine ignition switch (located beneath the front cover) through ON to GL. This engages the glow plug pre-heat system. Hold for 3-5 seconds then turn key fully to ST (start) position and the engine will start.
- 8) **WARM ENGINE:** - turn the main engine ignition switch (located beneath the front cover) through ON to ST (start) position and the engine will start.

PETROL (GASOLINE) ENGINE BI-ENERGY MODELS

- 6) If **ENG** (engine) is selected go to Step 7 for a **COLD ENGINE** or Step 8 for a **WARM ENGINE**.
- 7) **COLD ENGINE:** - turn the engine fuel tap on and engage the choke lever. Turn the main engine ignition through ON to ST (Start) and the engine will start. Return the choke lever to its normal running position after the engine has started.
- 8) **WARM ENGINE:** - turn the engine fuel tap on and turn the main engine ignition through ON to ST (start) position and the engine will start.

ALL MODELS

- 9) Push and hold green power button.
- 10) Select function and operate hand levers in full accordance with manufacturers operating and safety manual.
- 11) To return control to platform turn key fully clockwise to up position, and return function selector hand valve to **Platform** position, (i.e. fully up).
- 12) When not in use return machine to stowed position, turn the key to centre off position, remove key and chock wheels.

EMERGENCY PROCEDURES

- 1) Push in red emergency stop to shut down all functions, and select ground control by moving the function selector hand valve to the **Ground** position, (i.e. fully down).
- 2) Operate manual hand pump (located adjacent to the ground control valve) and manoeuvre the machine on the Ground hand lever controls.

4.2.2 BOOM OPERATION

- 1) Push and hold green power button.

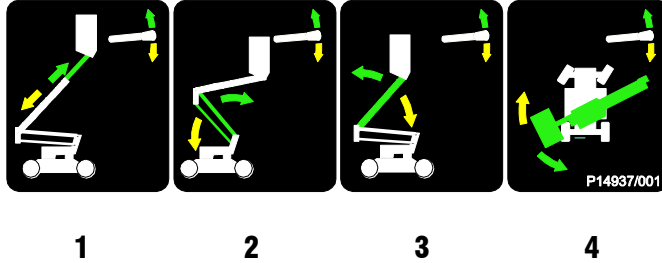

- 2) Select lever 1, 2, 3 or 4 for desired boom function.

1 Operates Telescope	UP for out	DOWN for in
2 Operates Lower Boom	UP for up	DOWN for down
3 Operates Upper Boom	UP for up	DOWN for down
4 Operates Swing	UP for right	DOWN for left



ALWAYS ENSURE THE AERIAL PLATFORM IS ON A FIRM LEVEL SURFACE AND THE AREA IS FREE OF ANY OVERHEAD OBSTRUCTIONS.

ENGAGING THE RED EMERGENCY STOP BUTTON WILL SHUT DOWN THE ENGINE AND THE ELECTRIC CIRCUIT, PREVENTING OPERATION OF ANY FUNCTION.

4.3 PLATFORM CONTROL OPERATION

4.3.1 PLATFORM CONTROL STATION

NEVER START THE NIFTYLIFT IF YOU SMELL PETROL (GASOLINE), LIQUID PROPANE OR DIESEL. THESE FUELS ARE FLAMMABLE.

BEFORE OPERATING THE NIFTYLIFT ENSURE THAT EACH OPERATOR HAS READ AND FULLY UNDERSTOOD THE OPERATING MANUAL. FAILURE TO DO SO MAY RESULT IN DEATH OR SERIOUS INJURY.



ALL MODELS

- 1) Ensure all red emergency stops are out.
- 2) Turn key switch at ground control station to **Platform** position (i.e. fully up).
- 3) Ensure function selector hand valve is turned to **Platform** position, (i.e. fully up)
- 4) Turn duty selector in platform to **BATT** (Battery) or **ENG** (Engine).
- 5) Battery electric models go to step 10.

DIESEL ENGINE OR BI ENERGY MODELS ONLY

- 6) If **ENG** (Engine) is selected go to Step 7 for **COLD ENGINE** or Step 8 for a **WARM ENGINE**.
- 7) **COLD ENGINE:** - Turn the 3 position engine ignition switch to the left, and hold for 3-5 seconds, this engages the glow plug pre-heat system. Then turn key fully to the right and the engine will start. When released, the selector will return to the centre, '**OFF**' position.
- 8) **WARM ENGINE:** - Turn the 3 position engine ignition switch to the right and the engine will start. When released, the selector will return to the centre, '**OFF**' position.

PETROL ENGINE OR PETROL/ELECTRIC MODELS ONLY

- 6) If **ENG** (Engine) is selected, ensure the fuel tap is turned to the ON position and then go to Step 8 for **COLD ENGINE** or Step 9 for a **WARM ENGINE**.
- 7) **COLD ENGINE:** - (From the ground only) turn the engine fuel tap on and engage the choke lever. Turn the main engine ignition through ON to ST (Start) and the engine will start. Return the choke lever to its normal running position after the engine has started.
- 8) **WARM ENGINE:** - Ensure the main engine ignition switch is ON. Turn the 3 position engine ignition switch to the right and the engine will start. When released, the selector will return to the centre, '**OFF**' position.

ALL MODELS

- 9) Ensure key switch selector is turned to **ON** or **BATT** (Battery) if applicable.
- 10) Depress foot switch or push and hold green power button.
- 11) Select function and operate hand levers in full accordance with manufacturers operating and safety manual.
- 12) When not in use return booms to stowed position. Turn key switch at ground control to centre off position, remove key and chock wheels.

4.3.2 BOOM OPERATION

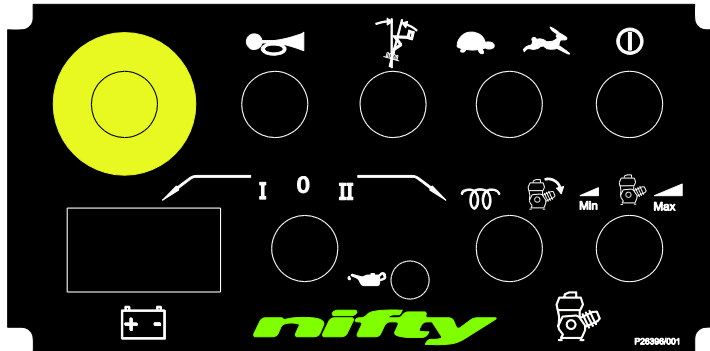

**(HR12N BI-ENERGY
MODEL SHOWN)**

- 1) Depress foot switch or push and hold green power button.

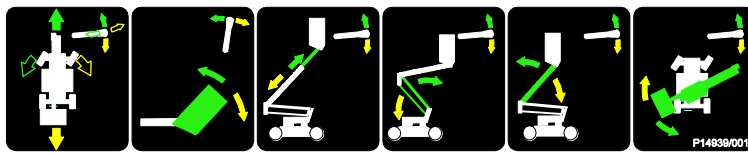

- 1
- 2
- 3
- 4
- 5
- 6

- 2) Select lever 1, 2, 3, 4, 5 or 6 for desired boom function.

1 Operates Drive and Steer (refer to Section 4.4)		
2 Operates Platform Level	FWD for fwd	BACK for back
3 Operates Telescope	UP for out	DOWN for in
4 Operates Lower Boom	UP for up	DOWN for down
5 Operates Upper Boom	UP for up	DOWN for down
6 Operates Swing	UP for right	DOWN for left

Operating & Safety Instructions

4.3.3 SiOPS™ - LOAD SENSING BAR (If fitted)



WHEN OPERATING THIS MACHINE THE USER MUST BE AWARE OF ANY OVERHEAD OBSTRUCTIONS.

This machine incorporates a load sensing bar that senses if the operator has been pushed or has fallen against it. If the load applied to the front of the bar is greater than the pre-determined amount, the footswitch will be disabled to increase operator safety and reduce the possibility of sustained involuntary operation of the cage controls.

Note: The green button will illuminate once the footswitch has been disabled, but continues to be available for use at all times. This allows the operator to use the cage control functions and manoeuvre the machine to a safe position.

To reset the footswitch:

- 1) Release the load from the front of the bar.
- 2) Ensure cage controls are in the neutral position and clear of objects.
- 3) Raise foot clear of footswitch then lower foot onto footswitch.
- 4) Footswitch is now active and full control has been restored.

Note: If SiOPS™ has been activated and the footswitch is not reset within **15 seconds**, then the blue warning beacon will flash (If fitted, located on the outside of the cage) and a warning announcement will sound until the footswitch is reset as described previously.



IN ORDER TO MAINTAIN THE SAFETY OF THE MACHINE, THE OPERATION OF THE LOAD SENSING SAFETY BAR SHOULD BE CHECKED EACH DAY BEFORE USE. IN THE CASE OF A MACHINE NOT RESPONDING TO THE OPERATION OF THE SAFETY BAR IT SHOULD BE REMOVED FROM SERVICE IMMEDIATELY.

UNDER NO CIRCUMSTANCES SHOULD THE SAFETY BAR BE REMOVED OR DISABLED BEFORE USING THE MACHINE. IF IN DOUBT, INFORM YOUR SUPERVISOR BEFORE ATTEMPTING TO USE THE MACHINE.

4.4 DRIVING CONTROLS



DO NOT OPERATE THE NIFTYLIFT WHILST ELEVATED UNLESS ON A FIRM, LEVEL SURFACE FREE FROM ANY POSSIBLE OBSTRUCTIONS OR HAZARDS BOTH AT GROUND LEVEL AND OVERHEAD.

- 1) Check proposed route for possible hazards, obstructions and personnel.
- 2) Push green power button or depress foot switch located in platform floor (if applicable).
- 3) Use the **Drive Speed** selector on the platform control station to determine speed.
High Drive (Hare) - GIVES HIGH SPEED AND LOW GRADEABILITY.
Low Drive (Tortoise) - GIVES LOW SPEED AND HIGH GRADEABILITY.
N.B. High Drive is only available when the booms are in the stowed position. The HR12 will default to Low Drive speed whenever the booms are elevated.
- 4) Select drive joystick from the platform control box.
 - A. Up for **FORWARD**
 - B. Down for **REVERSE**
 - C. Left for **STEER LEFT**
 - D. Right for **STEER RIGHT**
- 5) All control levers give a fully proportional response therefore the more the lever is moved away from the centre (OFF) position the faster the function will become.
- 6) Maximum drive speed is only attainable when all booms are fully stowed and the speed selector is in the **High Drive** position.
- 7) When driving with the booms fully stowed, the Tilt Alarm is bypassed to allow the Niftylift to be driven in areas where the slope exceeds the working limit. In normal operation the drive is therefore unaffected when driven onto a slope in excess of the working limit, until the booms are raised, whereupon the drive would be disabled and the tilt alarm sounds continuously.
- 8) Under no circumstances should any Niftylift SP series machine be driven on slopes **exceeding 25%**, with the booms fully stowed.



ALL NIFTYLIFTS ARE FITTED WITH A TILT ALARM - PRE-SET IN THE FACTORY. ONCE ENERGISED, THE NIFTYLIFT WILL LOSE ALL POWER TO DRIVE FUNCTIONS AND A LOUD AUDIBLE ALARM WILL BE ACTIVATED.

TO DE-ACTIVATE, LOWER THE BOOMS FULLY TO STOWED POSITION AND RE-POSITION BASE ON FIRM, LEVEL GROUND.

IF ALARM SOUNDS - DESCEND IMMEDIATELY AND RE-LEVEL MACHINE BASE.

Operating & Safety Instructions

4.5 CAGE WEIGH SYSTEM

4.5.1 LOAD CELL

The Niftylift HR12 is fitted with an electronic load cell. This load cell is a moment-independent design. This means that independent of the load position inside the machine cage, the actual load is measured and if pre-calibrated limit values are exceeded, warnings will be activated. If load exceeds the safe working limit (SWL) of the machine, the machine will be disabled until the load is reduced to below 95% of the safe working limit. The design of the unit meets the requirements of both BS EN280 and ISO 13849 with a safety integrity level of "Category 3 PL d. (Refer to Appendix A)

4.5.2 CALIBRATION, INSPECTION AND MAINTENANCE

Calibration, maintenance and repair of the Niftylift HR12 cage load cell requires specialist knowledge and equipment. **For this reason, no part of the Niftylift HR12 cage-weigh system can be adjusted, repaired or inspected by the operator.**

All enquiries relating to calibration, inspection or maintenance should be directed to Niftylift or one of their approved dealers. Contact details are listed in Section 1.3.

4.6 BATTERIES AND CHARGING



BATTERIES MUST BE RECHARGED IN A WELL-VENTILATED AREA FREE OF FLAME, SPARKS OR OTHER HAZARDS THAT MAY CAUSE EXPLOSION. HIGHLY EXPLOSIVE HYDROGEN GAS IS PRODUCED DURING THE CHARGING PROCESS.

- 1) Recharge batteries at the end of every working day or shift.
(**Note:** To recharge batteries fully from flat takes approx. 12 Hours, this consists of 8 hours bulk charging plus 4 hours equalisation).
- 2) Plug charger into suitable power supply, either 230 volts or 110 volts AC (see **Charging Limitations**). (Note: If using 230V, use of a suitably rated Earth Leakage Circuit Breaker (ELCB) or Residual Current Device (RCD) at the point of supply is highly recommended.)

Press **green power button** briefly to energise a motor contactor. This activates the Control Battery Regulator allowing it to charge the 12v engine battery at the same time as the main batteries.

- 3) Take note of the indicators provided:

Red Light - Batteries are charging.

Pulsing Green light - the charge is equalising.

Constant Green light and pulsing Red light - the batteries are fully charged.



UNDER NO CIRCUMSTANCES SHOULD BATTERIES BE LEFT ON CHARGE FOR PERIODS IN EXCESS OF 24 HOURS

- 4) **DISCONNECT FROM POWER SUPPLY ONCE BATTERIES ARE FULLY CHARGED.** The machine can now be left unattended, however, in the event of the machine being left unused for extensive periods then a **4 to 6 hour** 'top-up' charge every **4 weeks** is recommended. A 'top-up' charge the day before use ensures a full day of operation from the machine.



UNDER NO CIRCUMSTANCES SHOULD A MACHINE BE LEFT FULLY DISCHARGED AS SEVERE BATTERY DAMAGE CAN OCCUR IN A RELATIVELY SHORT TIME.

- 5) To avoid damage to charger disconnect from mains supply before using machine.

Note:

- 1) If the charger is reconnected to the power supply shortly after it has gone through its full charging cycle the Red LED may come on although the batteries may be fully charged. The charger would then go through its complete cycle again at an accelerated rate, depending on the time difference between connection, reconnection and level of battery charge.

Operating & Safety Instructions

- 2) Some Niftylifts are fitted with a Battery Management System, which permanently monitors the condition of the batteries. When the batteries become discharged to 20% of their capacity the management system will begin to "shut down" the hydraulic power packs. This causes the drive/boom operating system to alternately stop and start, signalling to the operator that re-charging is necessary. However, there is sufficient power remaining to enable the operator to drive slowly to the nearest charging point.

Should the operator ignore the onset of the battery discharge warning the "shut down" of the motors will continue, until the machine is rendered in-operative. **Immediate charging will then be required.**

CHARGING LIMITATIONS

Battery charging times will increase slightly if using a 110V supply as opposed to a 230V supply. This is due to the connection of the primary coils being in parallel, which in effect only allows the transformer to see 220V. Similarly, the capacity of the 110V supply will decide the input current available; hence a small hand-tool transformer will not operate the battery charger efficiently, therefore:
- charging times will increase further due to input limitations.

Attention should also be given to the use of extension cables as power leads. Excessive cable lengths from the supply point to the battery charger will result in significant voltage drop, leading to a reduction in the charger's efficiency. In addition, inadequate sized cable cores will have a limiting effect on its current carrying capacity, which will again lead to a reduction in the charger's efficiency. Both of these can result in over-heating of the cable with the attendant risk of fire, short circuits or damage to the components themselves.

The charger requires a minimum battery voltage of 4.5 volts per battery (overall for two batteries 9 volts, for 4 batteries 19 volts for 8 batteries 38 volts). If the voltage is below these values then the charger will not function (Charger will not detect batteries to begin charge.) If the batteries have fallen to such a poor state they will have to be removed from the machine and charged individually with an independent charger until the optimum voltage has been reached. This is best performed at very low currents to 'recover' the batteries if sulphation has already started i.e. a 'trickle' charger. This can take several hours, possibly days. Careful monitoring of the rise of battery voltage will indicate when recovery has been achieved.

TOPPING UP

During the course of normal operation, the batteries should be inspected at least once a fortnight to check the level of electrolyte. During the end of charge, gassing takes place, which will cause a slight reduction in the volume of acid in the battery. This can be topped up with de-ionised water as required. During this inspection, it is useful to note any imbalance in the fluid levels. One indication of a faulty cell would be an increase in the loss of battery acid, which would then require more frequent topping up on that cell, or cells. Faulty cells can liberate excess hydrogen, even during normal operation, with the resulting risk of explosion if ignited. **Any faulty batteries should be replaced as soon as possible with an equivalent sized and rated unit.**

Note: BATTERIES CONTAIN ACID, therefore: - protective safety glasses and gloves (Appropriate PPE) MUST be worn whilst performing these checks.

4.7 TRANSPORTING, TOWING, CRANEAGE, STORAGE AND SETTING TO WORK

4.7.1 TRANSPORTING

If a work platform is to be moved over a longer distance, whether the machine is trailer mounted, vehicle mounted, self propelled or tracked, the following procedure should be read before restraints are attached to the machine. Cross loading is most frequently the cause of problems, as the method of loading is no longer in sight of our own personnel. The recommendations made herein should be passed on to subsequent carriers, such that the entire journey is carried out without incident.

- Always ensure the truck or trailer you are loading or towing the Niftylift with can carry it legally.
- If loading by crane the use of shackles and an adequately rated spreader beam, with four leg slings, is **MANDATORY**.
- When loading or un-loading from the side of the vehicle, the use of the forklift pockets to retain one of the forks is recommended. (If fitted). Spread the forks to their widest capacity, with due regard to the components fitted to the machine. Never forklift or crane an entire machine under the booms, always lift beneath the spine or under the ends of the axle mountings in the case of a self-propelled unit. Ensure forklift is adequately rated for the load to be carried.
- Once positioned on the transport carrier ratchet straps should be used to secure the machine. The machine should be positioned to allow easy access around the machine in transit, and to ensure that 'creepage' during transport does not permit the machine to come into contact with other goods being shipped, or the container itself. Some movement of the machine structure might occur during transit, which could lead to fretting or other damage.
- If the machine is equipped with a transit device such as a boom clamp etc, this should be securely applied.
- Strap booms carefully to constrain them from sideways movement. When using straps or chains, adequate packing should be applied to stop any damage to the structure and paintwork. Due regard of the movement of the straps or chains must be taken into account.
- Where a machine has designated points for strapping, lifting or forking, these can be used for tie-down duty. When they are absent, the major structure of the platform can be used, giving due consideration to the design and function of the area chosen. Where possible, use the spine of the machine or axle mounts over which to apply the holding down forces. Using a single plate, such as an outrigger or stabiliser support plate might be unsuitable. If the component was clearly not designed to accommodate a side load, one should not be applied.
- Under no circumstances should straps or chains be applied over booms or through the cage support structure or the cage itself. The relative strength of the carrying structure is not conducive to the massive forces capable of being applied through ratchet chains or slings. Severe damage to the steelwork can be caused, as well as deformation to sensitive mechanisms such as cage weigh assemblies, which would render them useless. Such catastrophic damage to say, an electronic load cell would require the component to be replaced before the machine would function.

Operating & Safety Instructions

4.7.2 TOWING - Gearbox Drive motors with integral hydrostatic brakes

For towing the Niftylift in case of an emergency.

- 1) If parked on a slope securely chock all wheels.
- 2) Remove rear cover: locate brake release valve and turn anti-clockwise. The rear wheel motors are now free of the hydraulic circuit.
- 3) From within the ground control panel, move the brake override lever to the horizontal position. Fit the manual hand pump handle and give the hand pump several pumps until pressure is felt to build. A visual check of the brake telltale (Located next to the Drive Control Valve) will indicate when the brakes are released. When the indicator knob comes out of the block, the brakes are 'Off'.
- 4) The Niftylift can now be towed over short distances - **maximum speed 5mph**.
- 5) To re-set the brakes, move the brake override lever back to the normal 'up-right' position. The telltale indicator will return flush into the block. It might be necessary to cycle the lever more than once to re-set the brakes.
- 6) In order to drive the machine once more, the brake release valve will need to be closed, by turning clockwise. The wheel motors are now re-connected to the hydraulic circuit.
- 7) If the brake override lever is not re-set manually, the next time the machine is moved hydraulically, the brakes will automatically re-set themselves. The brake override lever will however be in the wrong position for emergency operation of the booms, and should be returned to the normal 'up-right' position as soon as possible.

HR12 4x4 Only - Brake override and towing

To enable towing of the HR12 4x4 in case of an emergency.

- 1) If parked on a slope securely chock all wheels.
- 2) Ensure the 'brake release tap' is fully closed, i.e. wound clockwise.
- 3) Locate hand pump handle onto hand pump and pump several times until the brake 'telltale' pops out from the side of the 'drive control valve block'. The brakes are now hydraulically released.
- 4) Open the bypass circuit by turning the red knob on the 'drive control valve block' a couple of turns anti-clockwise. The motors are now free to turn.



NOTE – THE MACHINE IS NO LONGER RESTRAINED FROM ROLLING AWAY AND MUST BE POSITIVELY HELD BY SOME OTHER MEANS (SEE ABOVE).

- 5) The machine can now be towed a short distance with the oil re-circulating around the drive circuit.

Re-setting the drive system

- 1) Before the machine will drive again, the red knob on the 'drive control valve block' must be wound fully shut (clockwise until tight). Failure to do so will render the drive function inoperative.
- 2) To restore the brake function, turn the 'brake release tap' a couple of turns anti-clockwise. When the 'telltale' in the side of the 'drive control valve block' pops back in, the brakes are now holding.
- 3) Wind the 'brake release tap' fully closed i.e. clockwise until tight. The machine is now ready to drive, brake and hold on a slope.
- 4) Once the 'drive control valve block' red knob has been fully closed, driving the machine forwards or backwards will also automatically re-set the brake circuit.
- 5) Remove the hand pump handle and replace in the clips.

4.7.3 CRANEAGE

- 1) Observe all of the limitations relating to straps and chains stated above under 'Transporting'. (4.7.1)
- 2) When utilising the designated lifting points never apply a 'snatch' load, i.e. lift slowly to take up the load before raising. Similarly, do not drop machine when positioning after lifting.
- 3) If the machine is to be lifted by crane, use the designated lifting points and observe the recommendations regarding spreader beams. Individual drawings are available for each machine type, on request. (See list below.)

D80461

D81795

D81790

D80938

HR10/12

HR15N/17N

HR15/17 4X4/Hybrid Mk2

HR21

4.7.4 STORAGE

If being stored for any length of time without use, then the machine should be thoroughly inspected for the following:-

- 1) Grease all bearings /slides, worm drives, etc.
- 2) Check batteries for electrolyte levels, state of charge, damage, dirt, etc. Never leave in a state of discharge for any length of time. If no use of the platform is intended, an occasional "top-up" charge of the batteries will serve to equalise their charge level.
- 3) Leave battery disconnect switch in OFF position to prevent discharge of batteries through leakage.
- 4) If machine is to be left on an incline, chock wheels to prevent creep.
- 5) If machine is to be left outside or in a hostile environment, cover with suitable weatherproof media to prevent deterioration.

Operating & Safety Instructions

4.7.5 SETTING TO WORK

Before use each day and at the beginning of each shift the machine shall be given a visual and functional test including, but not limited to, the following

- 1) Check all lubrication points for adequate application of grease, oil etc.
- 2) Inspect all threads for ease of operation - especially descent valves, brake release valve etc.
- 3) Check level and quantity of oil. Remove any contaminants - water, etc.
- 4) Check batteries for electrolyte and state of charge.
- 5) Check electrics for damage and insulation.
- 6) Using ground controls, cycle machine over complete envelope in accordance with the Operating Instructions. Cure any defects.
- 7) Ensure that all safety devices and controls operate in accordance with the instructions.
- 8) If necessary, perform a load test to establish the machine stability before putting the machine to work.
- 9) On completion of an extended period of road transport, the machine might need additional inspection to identify any transit degradation, which could render the machine unsafe. Perform a P.D.I. inspection on the unit before it enters service. Record any faults found and rectify them immediately.
- 10) If left un-attended for an extended period, it is likely that the hydraulic cage levelling will become un-pressurised. Normal operation is then lost, with a noticeable delay in the forwards or backwards motion as the booms move. To restore normal function, the cage needs to be fully levelled forwards and backwards, using the cage-levelling lever whilst **not** standing in the cage (i.e. with the operator standing adjacent to the cage side whilst simultaneously operating the lever and green button to move the cage). Take care not to become trapped between the moving cage and a fixed object, and ensure those around you are clear of the moving cage. When the system has been charged in both directions, the cage levelling function should be restored. If the system operates but is 'jerky' in either direction, this indicates air in the system. Repeat the procedure as described above until the movements are smooth and un-interrupted. If in doubt, contact our Service Department for further advice.

Niftylift Limited is not liable for any third party damage caused during transport. Careful attention to correct procedures will prevent many of the small snags that can happen in transit. Re-work is both expensive and time consuming. A defective machine arriving at the place of work is a poor advertisement for our product, the company's reputation and those of our dealers and clients. The responsibility for safe and damage-free transport rests with the haulier or his representatives.

5 Emergency Controls

5.1 GENERAL

CHECKING THE OPERATION OF THE EMERGENCY CONTROLS EVERY DAY AND/OR BEFORE EACH SHIFT IS AN ESSENTIAL PART OF THE OPERATOR'S DUTIES



The operator and all ground personnel must be thoroughly familiar with the location and operation of the emergency controls.

5.2 IN THE EVENT OF AN INCAPACITATED OPERATOR

Turn the key switch at the ground control station to **Ground** (Anti-clockwise). Ensure function selector hand valve is turned to **Ground** position (i.e. fully down). Manoeuvre the machine using the ground controls as described previously in Section 4.2.

5.3 IN THE EVENT OF MACHINE FAILURE

If all machine power is lost, the **Manual Hand pump** can be used to provide the hydraulic power to manoeuvre the machine. Operating the Manual Hand pump provides flow to the valve block selected at the ground controls. Hence the ground person can give hand pump flow to enable the **Platform** operator to move the machine, or control can be taken at the **Base** as described above, to enable the ground operator to pump and at the same time, manoeuvre the machine using the Ground hand levers. If initial movement of the machine allows the master alarm to reset, normal controls will be available. This is then the fastest method of lowering the platform to the ground.

Note: If the machine is fitted with a cage overload system, and the cage comes into contact with a fixed object whilst operating at height, this would be detected as an overload condition. All power to the machine controls would be lost, requiring the machine to be recovered using the **Manual Hand Pump**. It is sufficient for the cage to be manoeuvred away from the collision point to re-set the cage weigh mechanism, thereby restoring normal machine operation. The cage could then be brought down using the controls as described previously.

FOLLOWING AN EMERGENCY DESCENT RECOVERY OF THE PLATFORM, FULLY EXTEND AND RETRACT ALL CYLINDERS FROM GROUND CONTROL STATION BEFORE USING THE MACHINE.



5.4 INCIDENT NOTIFICATION

It is a mandatory requirement that any accident or incident involving a Niftylift, regardless of whether any party received injury or property was damaged is reported by telephone directly to Niftylift. Failure to do so may render any warranty on the machine void.

6 Responsibilities

6.1 CHANGES IN OWNERSHIP

When a change of ownership of a Niftylift occurs, it shall be the responsibility of the seller to notify Niftylift direct of the unit, model and serial number and the name and address of the new owner within 60 days. This important step is required so that all future Technical Bulletins are able to reach the registered owner of each machine without delay. Please note warranties are not transferable.

6.2 Inspection/Service/Pre-Hire Check list

MACHINE SERIAL NO _____

TOWING	PASS	FAIL	N/A
Machine secured on trailer			
Straps correctly positioned and tightened			
Wheels chocked if necessary			
AXLES, WHEELS AND BRAKES			
Wheels are secure, tyre condition acceptable			
Wheel bearings O.K.			
Brake linkages and cables secure			
Brake shoe wear not excessive			
Machine climbs slope			
Brakes hold machine on slope			
Rear hub nut secure			
Track rod secure, not fouling axle plate			
BASE			
Operation of ground control valve and buttons			
Operation of all booms over full range			
Wheel bearings OK			
Cylinders are silent			
Platform is level over full range			
Booms, levelling rods not damaged or distorted			
Booms levelling rods, cylinders not fouling			
Hoses not tight, kinked or fouled			
Operation of manual hand pump			
SLEWING			
Slew assembly and motor are secure			
Worm/wheel mesh correct, no excessive wear			
No end float of worm in housing			
Slew wheel bolts secure			
Slew guards secure			
PLATFORM			
Operation of control valve and buttons			
Operation of SiOPS			
Levelling lock valve holds in both directions, lines vented			
Operation of all booms over full range			
Cylinders are silent			

nifty Height Rider/SP Series

Operating & Safety Instructions

PLATFORM (continued)	PASS	FAIL	N/A
Platform levelling over full range			
Slewing smooth over full range			
Operation of telescopic boom over full range			
No excessive movement of telescopic boom			
TILT ALARM			
Booms raised on slope - drive disabled, siren tone constant			
Boom operation unaffected			
Booms lowered - drive restored			
INTERNAL (POWER PACK)			
Power pack and all components secure			
All cables and terminals secure			
All hose connections secure			
Hoses not kinked or fouled			
Charger/control box secure			
Batteries secure			
Electrolyte level and specific gravity			
Charger operation			
Hydraulic oil level			
Engine/Gear box oil			
FINISH			
Pivot pin tag bolts			
Correct decals, all visible			
Canopy/bonnets			
Grease nipples (Feet, Knuckle, Centre Post)			
LEAK CHECK			
Cylinders (Lift, Jacks, Telescope, Levelling)			
Control valves			
Check valves			
Power pack/pump			
Slew motor			
Hose connections			
Filter			
Wheel motors			

Comments, remedial work required etc;

INSPECTED BY: _____ **DATE:** / /

Appendix A

Safety Related Parts of the Control System (SRP/CS)

The Niftylift control system has been designed and validated according to the required standards. The table below lists the safety related parts of the control system and the level to which they have been approved.

The performance level (PL) of each SRP/CS is specified by BS EN 280:2013 section 5.11 Table 4.

Safety Related Part of the Control System (SRP/CS)	Approval (Standard, Performance Level)
A1 Prevent travel above inclination limit	ISO 13849-1:2008 PL c
A2 Limitation of travelling speed	ISO 13849-1:2008 PL c
A3 Load sensing system	ISO 13849-1:2008 PL d
A4 Platform levelling	ISO 13849-1:2008 PL c
A5 Interlocking of control positions	ISO 13849-1:2008 PL c
A6 Prevent movements of load holding cylinders in case of pipe failure	ISO 13849-1:2008 PL c
A7 Interlocking of travel controls	ISO 13849-1:2008 PL b

A1 PREVENT TRAVEL ABOVE INCLINATION LIMIT

The inclination interlock or Tilt System is PL c in accordance with ISO 13849-1:2008 as required by BS EN 280:2013

1. *The limits of the safety-related parts to the category selected and any fault exclusions;*

The tilt interlock is only active when the telescoping booms are lifted up off the boom rest such that the boom switch is actuated.

The boom switch relies on the electrical contacts opening allowing the tilt system to permit drive within the rated angle.

The opening of the contacts is forced by the use of the spring contained within the booms down switch assembly. **Proper maintenance and daily safety checks to be observed**

The boom switch cannot be overridden to bypass the tilt system other than by demounting the switch with the use of tools. **Reasonably foreseeable misuse**

If the boom switch is removed or if it is not maintained in accordance with the appropriated documentation the tilt system may not function in compliance with the requirements as a PL c device.

2. *The limits of the SRP/CS and any fault exclusion, for which, when essential for maintaining the selected category or categories and safety performance, appropriate information (e.g. for modification, maintenance and repair) shall be given to ensure the continued justification of the fault exclusion(s);*

Do not alter, modify or disable in any way the controls, safety devices, interlocks or any other part of the machine.

Operating & Safety Instructions

Maintenance must only be carried out by appropriately trained and competent persons.

3. The effects of deviations from the specified performance on the safety function(s);

If the tilt interlock does not function as intended it is possible that the Niftylift may encounter slopes for which it is not rated.

If the Niftylift encounters slopes beyond the rating as specified on the serial plate the product may occur instability.

If the product becomes unstable, damage to the Niftylift, other equipment and properties, injury or loss of life of the operator and surrounding persons may be a risk.

4. Clear descriptions of the interfaces to the SRP/CS and protective devices;

The tilt system comprises of a primary device the “tilt sensor” the booms down switch, and control PCBs, and protective devices, for example solenoid operated hydraulic valves or contactors.

If the drive forward or backwards functions are selected when on the boom rest the drive functions will be available regardless of angle of inclination.

If the drive forward or backwards functions are selected when off the boom rest the output from the tilt sensor not being present will deny drive functions.

5. Response time

The tilt sensor is active at all times providing the correct signal in relation to the angle of inclination of the chassis. In the event of encountering an angle of inclination greater than allowable the system will prevent drive functions from being performed until the booms have been lowered on to the boom rest and the angle of inclination has been corrected.

6. Operating limits (including environmental conditions);

All components within the tilt interlock are rated to the environmental conditions acceptable for the machine; refer to Section 2.2.

7. Indications and alarms;

Tilt alarm

The action of the tilt alarm will cause the klaxon to sound and will be indicated by the red warning light on the base and cage location, if the booms are raised and the allowable tilt limit is detected

Tilt sensor fault codes.

Code	Blinks	Meaning
1	1	Internal error - Ask BPE Srl Slave micro controller communication error
2	-	Not used
3	3	Main “ID” safety output error
4	4	Digital inputs check error WQ
5	5	CRC memory error (1). Ask BPE Srl CRC EEPROM
6	-	Not used
7	7	Internal cross check error on X axes. Ask BPE Srl
8	-	Not used

9	5	CRC memory error (1). Ask BPE Srl CRC RAM
10	5	CRC memory error (1). Ask BPE Srl CRC flash
11	-	Not used
12	7	Internal cross check error on Y axes. Ask BPE Srl

8. Muting and suspension of safety functions;

While the tilt sensor is always active both the drive interlock is suspended while the booms are on the boom rest. The angle of inclination having been exceeded will be indicated via warning lights regardless of the boom position.

9. Control modes;

The tilt system has no user controllable modes of operation.

10. Maintenance; Maintenance check lists;

Normal maintenance

- Visual check of transducers, board (box) and connection wires.
- Check of power supply to verify it is correct.
- Check of the equipment correct operation, by simulating a locked condition and correspondent rearming. See “Means for easy and safe trouble shooting”
- Check correct operation of the boom switch.

The tilt sensor will not normally require special maintenance. Should special maintenance be required please observe the following precautions.

- Cut off power supply before every check or replacement.
- Do not weld on machine structure before removing power supply (positive and negative) and detaching boxes from vehicle frame or possible connections towards vehicle frame.
- Provide suitable mechanical protections for connection wires, paying particular attention for transducers.
- Do not place board, transducers or cabling close to sources of heat, electromagnetic interferences or power transmissions.
- Do not touch directly boards, transducers and boxes with flushing or degreaser fluids under pressure.
- Do not hole the board box.
- Seal the box and/or the panel who contains the electronic board, to reveal any not authorized access or tampering.

11. Ease of accessibility and replacing of internal parts;

Replacement of parts should only be carried out by appropriately trained and competent persons.

If parts require replacement only replace the whole such as Tilt Sensor, Safety Switch, PCB or Hydraulic valve block.

Do not attempt to open the tilt sensor or replace components soldered to any PCB.

Do not attempt maintenance of hydraulic components i.e. replace seals or internal component.

Only Niftylift original and supplied parts shall be used.

Operating & Safety Instructions

12. *Means for easy and safe trouble shooting;*

To check the operation of the tilt sensor system

1. Power on the Niftylift and select the base control location.
2. Press the device upper side over the “X+” symbol, until maximum angle and check that green LED goes off.
3. Press the device upper side over the “Y+” symbol, until maximum angle and check that green LED goes off.
4. To check that the rest of the system is operating correct elevate the machine off of the boom rest the minimum amount to allow the booms switch to switch.
5. On the tilt sensor Press the device upper side over the “X+” symbol, until maximum angle and check that red tilt warning illuminates and the tilt alarm sounds
6. On the tilt sensor Press the device upper side over the “Y+” symbol, until maximum angle and check that red tilt warning illuminates and the tilt alarm sounds
7. Power off the Niftylift

13. *Information explaining the applications for use relevant to the category to which reference is made;*

Not applicable

14. *Checking test intervals where relevant.*

Check the operation of the tilt sensor system to be made at the beginning of every duty cycle.

A2 LIMITATION OF TRAVELLING SPEED

The limitation of travelling speed interlock, also known as the elevated drive speed system, is PL c in accordance with ISO 13849-1:2008 as required by BS EN 280:2013

1. *The limits of the safety-related parts to the category selected and any fault exclusions;*

The elevated drive speed system is only active when the telescoping booms are lifted up off the boom rest such that the boom switch is actuated or if applicable the telescope sections are extended sufficiently far to allow activation of the telescope switch.

The boom switch relies on the electrical contacts opening allowing the tilt system to permit drive within the rated angle.

The opening of the contacts is forced by the use of the spring contained within the booms down switch assembly. Proper maintenance and daily safety checks to be observed.

The boom switch cannot be overridden to bypass the tilt system other than by demounting the switch with the use of tools.

If the boom switch is removed or if it is not maintained in accordance with the appropriated documentation the elevated drive speed system may not function in compliance with the requirements as a PL c device.

2. *The limits of the SRP/CS and any fault exclusion, for which, when essential for maintaining the selected category or categories and safety performance, appropriate information (e.g. for modification, maintenance and repair) shall be given to ensure the continued justification of the fault exclusion(s);*

Do not alter, modify or disable in any way the controls, safety devices, interlocks or any other part of the machine.

Maintenance must only be carried on by appropriately trained and competent persons.

3. *The effects of deviations from the specified performance on the safety function(s);*

If the elevated drive speed interlock does not function as intended it is possible that the Niftylift may experience dramatic dynamic effects which may adversely affect the stability of the product.

If the product becomes unstable, damage to the Niftylift, other equipment and properties, injury or loss of life of the operator and surrounding persons may be a risk.

4. *Clear descriptions of the interfaces to the SRP/CS and protective devices;*

The elevated drive speed interlock consists of the booms down switch and/or the Tilt switch control PCBs and solenoid operated hydraulic.

If the drive forward or backwards functions are selected when on the boom rest the brake release valve will be energised allowing the drive functions to be used regardless of angle of inclination.

If the drive forward or backwards functions are selected when off the boom rest the output from the tilt sensor is required to energise both the brake release valve and the Master dump to enable drive functions.

5. *Response time*

The boom switch and telescope switch (if fitted) are active at all times providing the correct signal in relation to the position of the booms. With the booms in the raised position or with the telescope booms extended system will prevent high speed drive functions from being performed until the booms have been lowered on to the boom rest and the telescope booms have been retracted to the appropriate positions.

6. *Operating limits (including environmental conditions);*

All components within the tilt interlock are rated to the environmental conditions acceptable for the machine; refer to Section 2.2.

7. *Indications and alarms;*

There are no indicators or alarms to show that the Niftylift is under the control of the elevated drive speed interlock.

8. *Muting and suspension of safety functions;*

It is not possible to suspend the operation of the Elevated drive speed interlock with the booms raised or the telescope sections extended.

9. *Control modes;*

The elevated drive speed interlock has no user controllable modes of operation.

Operating & Safety Instructions

10. Maintenance; Maintenance check lists;

Normal maintenance

- Check correct operation of the boom switch.
- Check correct operation of the telescope switch.

11. Ease of accessibility and replacing of internal parts;

Replacement of parts should only be carried out by appropriately trained and competent persons.

If parts require replacement only replace the whole such as Safety Switch, PCB or Hydraulic valve block.

Do not attempt to open the booms switches, other than to check the condition of the wiring to the switches, or replace components soldered to any PCB.

Do not attempt maintenance of hydraulic components i.e. replace seals or internal component.

Only Niftylift original and supplied parts shall be used.

12. Means for easy and safe trouble shooting;

To check the operation of the elevated drive speed system

- 1) Ensure that the Niftylift has sufficient clearance in all directions to drive for a minimum distance to ascertain that the elevated drive speed is correct.
- 2) Power on the Niftylift and select the cage control location.
- 3) From the cage control elevate the links booms and extend the telescope sections in turn sufficient to remove the telescope sections from the boom rest such that the boom switch is actuated.
- 4) By the use of the drive forward and backwards functions in turn, depress the joystick trigger and depress the joystick in the desired direction.
- 5) Observe that the speed of the drive functions is no more than 1km/h. This can be characterised as a very slow walking pace.
- 6) Release the joystick to cease driving operations.

13. Information explaining the applications for use relevant to the category to which reference is made;

Not applicable

14. Checking test intervals where relevant.

Check the operation of the elevated drive system to be made at the beginning of every duty cycle.

A3 LOAD SENSING SYSTEM

The Load sensing system is PL d in accordance with ISO 13849-1:2008 as required by BS EN 280:2013

1. *The limits of the safety-related parts to the category selected and any fault exclusions;*

The load sensing system is activated whenever a green button of footswitch input is given to the PCB. The sensing system is a two-channel device which takes the input from a single load cell bridge on the cage load cell. The actual cage load is determined, and in the case of an overload, the alarm will sound and the output signal is lost.

The loss of the output signal is converted into two separate signals, one of which is used to isolate Channel 1 output (GBO) and the other to isolate the Channel 2 output. (EN). **Proper maintenance and daily safety checks to be observed.**

On initial set-up the machine must be zero loaded to allow the 'Tare' function to register the no-load condition. Following that a calibrated test load is put into the cage to set the upper limit. Proper adherence to the zero set point and the correct test load must be taken to ensure the load sensing system is working correctly. It is possible to apply the overload to the machine in the rest position, and then only to detect this on the next application of the command signal. If the machine has been in the elevated position the consequences of this would be more significant than if the machine were stowed.

Reasonably foreseeable misuse

2. *The limits of the SRP/CS and any fault exclusion, for which, when essential for maintaining the selected category or categories and safety performance, appropriate information (e.g. for modification, maintenance and repair) shall be given to ensure the continued justification of the fault exclusion(s);*

Do not alter, modify or disable in any way the controls, safety devices, interlocks or any other part of the machine.

Maintenance must only be carried on by appropriately trained and competent persons, who are conversant with all modes of operation, speeds and characteristics of this model.

3. *The effects of deviations from the specified performance on the safety function(s);*

If the load sensing system does not function as intended it is possible that the Niftylift may encounter overloads for which it is not rated.

If the Niftylift encounters loads beyond the rating as specified on the serial plate the product may occur instability.

If the product becomes unstable, damage to the Niftylift, other equipment and properties, injury or loss of life of the operator and surrounding persons may be a risk.

4. *Clear descriptions of the interfaces to the SRP/CS and protective devices;*

The load moment control system comprises of a primary device the "load sensor" and control PCB, and protective devices, for example solenoid operated Mater dump valves or contactors.

If the load sensing system cuts out, an alarm will sound and a clear indication of visual overload will be given at each operating position. The system will not re-set until the overload has been removed, by recommendation of reducing the overload in a safe manner.

Operating & Safety Instructions

5. *Response time;*

The Load sensing system is active all the time the green button or footswitch is depressed, the application of an overload will be detected within 4 seconds to cater for transient loads and acceleration forces. The alarm and visual indication will continue to sound as long as the machine is overloaded and the command signal is being applied. Removal of the overload by reduction of the applied load will take the cage weight below the threshold for activation as there is 95% hysteresis in the system. Once restored the load system will function as before and no re-calibration will be necessary.

6. *Operating limits (including environmental conditions);*

All components within the load sensing system are rated to the environmental conditions acceptable for the machine; see **Section 2.2**.

7. *Indications and alarms;*

The action of the cage overload detection will cause the klaxon to sound and will be indicated by the red warning light on the base and cage location, only as long as the green button or footswitch is continued to be depressed.

8. *Muting and suspension of safety functions;*

In the case of the overload being detected the alarm can be silenced by releasing the green button or footswitch. Suspension of the function will continue until the overload has been safely removed.

9. *Control modes;*

The load sensing system has no user controllable modes of operation, other than by use of the calibration tool.

10. *Maintenance; Maintenance check lists;*

Normal maintenance

- Visual check of transducers, board (box) and connection wires.
- Check of power supply to verify it is correct.
- Check of the equipment correct operation, by simulating an overload condition and correspondent re-setting. See "Means for easy and safe trouble shooting"

The load sensor will not normally require special maintenance

Should special maintenance be require please observe the following precautions.

- Cut off power supply before every check or replacement.
- Do not weld on machine structure before removing power supply (positive and negative) and detaching boxes from vehicle frame or possible connections towards vehicle frame.
- Provide suitable mechanical protections for connection wires, paying particular attention for transducers.
- Do not place board, transducers or cabling close to sources of heat, electromagnetic interferences or power transmissions.
- Do not touch directly boards, transducers and boxes with flushing or degreaser fluids under pressure.
- Do not hole the board box.
- Seal the box and/or the panel who contains the electronic board, to reveal any not authorized access or tampering.

11. Ease of accessibility and replacing of internal parts;

Replacement of parts should only be carried out by appropriately trained and competent persons.

If parts require replacement only replace the whole such as Load Sensor, PCB or Hydraulic valve block.

Do not attempt to open the load sensing PCB or replace components soldered to any PCB.

Do not attempt maintenance of hydraulic components i.e. replace seals or internal component.

Only Niftylift original and supplied parts shall be used.

12. Means for easy and safe trouble shooting;

To check the operation of the load sensor system

1. Power on the Niftylift and select the base control location.
2. Allow the power circuits to cycle and ensure the machine is ready for the command signal.
3. Press the base green button and observe that the machine is ready to function with no load in the cage. (Machine runs, pump flow is available for machine functions.)
4. Select the Cage control position and mount into the cage.
5. Enable the cage controls and then press the cage green button or foot switch to enable the machine functions. (Machine runs, pump flow is available for machine operation.)
6. Add sufficient load to the cage to exceed the safe working load. Press the green button or foot switch and observe that the cage overload system brings in the alarm and halts all machine movements.
7. Remove the overload to below the threshold for safe working load and observe that the cage load control automatically re-sets and restores all machine functions.
8. Power off the Niftylift.

13. Information explaining the applications for use relevant to the category to which reference is made;

Not applicable

14. Checking test intervals where relevant.

Check the operation of the load sensing system to be made at the beginning of every duty cycle.

A4 PLATFORM LEVELLING

The Platform levelling system is PL c in accordance with ISO 13849-1:2008 as required by BS EN 280:2013

1. *The limits of the safety-related parts to the category selected and any fault exclusions;*

The Platform levelling system comprises of a load holding device mounted to the slave levelling cylinder.

2. *The limits of the SRP/CS and any fault exclusion, for which, when essential for maintaining the selected category or categories and safety performance, appropriate information (e.g. for modification, maintenance and repair) shall be given to ensure the continued justification of the fault exclusion(s);*

Do not alter, modify or disable in any way the controls, safety devices, interlocks or any other part of the machine.

In the event of a hose failure ensure a recovery plan is in place that does not require the movement of the luffing booms as the angle of the cage will not be maintained. See effect of deviations from the specified performance below.

Maintenance must only be carried on by appropriately trained and competent persons.

3. *The effects of deviations from the specified performance on the safety function(s);*

If the levelling system of the product does not function as intended the angle of the cage may not be maintained.

If the angle of cage is not maintained there is an increased risk of ejection of tools and equipment from the cage;

In the event of the operator or other occupants of the cage not using the required safety equipment they may be ejected from the cage and serious injury or death may occur.

There is a load holding device contained within the assembly of the slave levelling cylinder such that if a hose fails the cage position is maintained until the operator can be recovered from the cage.

4. *Clear descriptions of the interfaces to the SRP/CS and protective devices;*

The levelling system comprises of two hydraulic cylinders and interconnecting hoses.

One is referred to as the Master levelling cylinder

The other is referred to as the Slave levelling cylinder.

In normal operation when the luffing booms are elevated the master levelling cylinder responds to the movement of the booms and causes a transfer of hydraulic fluid to the appropriate side of the slave levelling cylinder.

This transfer of hydraulic fluid maintains the level aspect of the cage.

5. *Response time*

The Levelling system is a direct acting hydraulic system and as such the response time is near instantaneous.

6. *Operating limits (including environmental conditions);*

All components within the tilt interlock are rated to the environmental conditions acceptable for the machine; see **Section 2.2**.

7. *Indications and alarms;*

There are no indicators or alarms to show that the Niftylift levelling system is functioning.

8. *Muting and suspension of safety functions;*

It is not possible to suspend the operation of the Elevated the levelling system

9. *Control modes;*

The levelling system has two modes of operation

- 1) Normal movements of the luffing booms cause the system to constantly adjust the cage angle to keep it level.
- 2) Manual adjustment to account for drift of the system over time.

10. *Maintenance; Maintenance check lists;*

Normal maintenance

- Removal of air from the hydraulic system if the product is left unused for long periods of time.

11. *Ease of accessibility and replacing of internal parts;*

Replacement of parts should only be carried out by appropriately trained and competent persons.

If parts require replacement only replace the whole components such as hoses, hydraulic cylinders or load holding and over centre valve.

Do not attempt maintenance of hydraulic components i.e. replace seals or internal component.

Only Niftylift original and supplied parts shall be used.

12. *Means for easy and safe trouble shooting;*

Elevate the luffing booms and check that the cage remains level. If the cage does not remain level the system should be serviced by trained persons fully conversant with the function of the system.

13. *Information explaining the applications for use relevant to the category to which reference is made;*

Not applicable

14. *Checking test intervals where relevant.*

Check the operation of the elevated drive system to be made at the beginning of every duty cycle.

A5 INTERLOCKING OF CONTROL POSITIONS

The interlocking of the control positions is PL C in accordance with ISO 13849-1:2008 as required by BS EN 280:2013

1. The limits of the safety-related parts to the category selected and any fault exclusions;

The physical interlocks between the multiple control positions are controlled through primarily electrical means such that neither position takes sole command unless selected. The alternate control position is then rendered inoperative by isolation of that control circuit. **Proper maintenance and daily safety checks to be observed.**

Since the physical installation of the electrical contacts is the means by which the control circuit operates it is imperative that the functionality is retained. If the internal wiring is interfered with the control isolation could be lost or altered in a way that promotes a dangerous mode of operation. **Reasonably foreseeable misuse**

2. The limits of the SRP/CS and any fault exclusion, for which, when essential for maintaining the selected category or categories and safety performance, appropriate information (e.g. for modification, maintenance and repair) shall be given to ensure the continued justification of the fault exclusion(s);

Do not alter, modify or disable in any way the controls, safety devices, interlocks or any other part of the machine.

Maintenance must only be carried on by appropriately trained and competent persons, who are conversant with all modes of operation, speeds and characteristics of this model.

3. The effects of deviations from the specified performance on the safety function(s);

If the interlocking of the control positions does not function as intended it is possible that the Niftylift may allow modes of operation that render it potentially dangerous.

If the controls do not remain independent in their operation, damage to the Niftylift, other equipment and properties, injury or loss of life of the operator and surrounding persons may be a risk.

4. Clear descriptions of the interfaces to the SRP/CS and protective devices;

Each control position is capable of being energised by means of a key operated 'mode selector' which electrically isolates the other circuit when one is selected. The reliability of this function depends on the correct device operator in conjunction with the appropriate contact and internal wiring.

5. Response time

Operation of the mode selector key switch is immediate. Control authority is transferred over and no residual power functions remain with the alternate control position, other than gravity descent (if used.)

6. Operating limits (including environmental conditions);

All components within the control interlock system are rated to the environmental conditions acceptable for the machine; see **Section 2.2.**

7. Indications and alarms;

None, other than by key position.

8. Muting and suspension of safety functions;

None.

9. Control modes;

The standard EU control circuit will permit independent operation of either control position, working through a series Emergency Stop control circuit. In some countries (e.g France and Australia) the alternate control interlock permits the cage system to be isolated by the ground control key switch and will ignore the use of the Cage Emergency Stop. This function effectively promotes the Ground control position to have overall authority over the machine, when selected.

10. Maintenance; Maintenance check lists;

Normal maintenance

- Visual check of switch operators, (Key switch) and connection wires.
- Check of power supply to verify it is correct.
- Check of the equipment correct operation, by selection of the alternate control position and then checking that the green button is inert at the non-selected position.

11. Ease of accessibility and replacing of internal parts;

Replacement of parts should only be carried out by appropriately trained and competent persons.

Individual parts of the control devices can be replaced, ensuring like-for-like exchange of parts, security of the wiring and polarity of components if applicable (Diode outputs etc.)

12. Means for easy and safe trouble shooting;

To check the operation of the load sensor system.

1. Power on the Niftylift and select the base control location.
2. Allow the power circuits to cycle and ensure the machine is ready for the command signal.
3. Press the base green button and observe that the machine is ready to function with no load in the cage. (Machine runs, pump flow is available for machine functions.)
4. Leave the base key in the ground control position and mount into the cage.
5. Enable the cage controls and then press the cage green button or foot switch to enable the machine functions. Check that no controls are active and that no functions are permitted with the key in the 'ground' control position.
6. Have the base key switch position altered to the Cage position. Check that the control functions are now transferred to the cage, and that all controls are active.
7. Dismount from the cage and check the ground controls are now inoperative. All checks are then complete.
8. Power off the Niftylift.

13. Information explaining the applications for use relevant to the category to which reference is made;

Not applicable

14. Checking test intervals where relevant.

Check the operation of the control position interlock to be made at the beginning of every duty cycle.

A6 PREVENT MOVEMENTS OF LOAD HOLDING CYLINDERS IN CASE OF PIPE FAILURE

The load holding system is PL c in accordance with ISO 13849-1:2008 as required by BS EN 280:2013

1. *The limits of the safety-related parts to the category selected and any fault exclusions;*

The load holding system comprises of a load holding device mounted to the master levelling cylinder.

2. *The limits of the SRP/CS and any fault exclusion, for which, when essential for maintaining the selected category or categories and safety performance, appropriate information (e.g. for modification, maintenance and repair) shall be given to ensure the continued justification of the fault exclusion(s);*

Do not alter, modify or disable in any way the controls, safety devices, interlocks or any other part of the machine.

In the event of a hose failure ensure a recovery plan is in place that does not require the movement of the affected cylinder. A safe route of recovery might involve the replacement in-situ of the failed hose before further movement of the machine is possible.

Maintenance must only be carried on by appropriately trained and competent persons.

3. *The effects of deviations from the specified performance on the safety function(s);*

If the load holding system of the product does not function as intended the angle of the security of the booms may not be maintained.

If the angle of cage is not maintained there is an increased risk of ejection of tools and equipment from the cage;

In the event of the operator or other occupants of the cage not using the required safety equipment they may be ejected from the cage and serious injury or death may occur.

There is a load holding device contained within the assembly of the slave levelling cylinder such that if a hose fails the cage position is maintained until the operator can be recovered from the cage.

4. *Clear descriptions of the interfaces to the SRP/CS and protective devices;*

The load holding system comprises of a pilot operated over centre valve on each load holding cylinder.

The opening of the load holding valve is dependent on the application of a pilot pressure in the descent line to bring the machine down. Excessive over pressure either by overload or thermal expansion can induce an over centre pilot descent until the excess pressure condition is removed.

5. *Response time*

The load holding system is a direct acting hydraulic system and as such the response time is near instantaneous.

6. *Operating limits (including environmental conditions);*

All components within the load holding system are rated to the environmental conditions acceptable for the machine; see **Section 2.2**.

7. *Indications and alarms;*

There are no indicators or alarms to show that the Niftylift load holding system is functioning.

8. *Muting and suspension of safety functions;*

It is not possible to suspend the operation of the load holding system.

9. *Control modes;*

The load holding system has two modes of operation

- 1) Normal movements of the booms cause the system to constantly adjust the cylinders to maintain machine position and load holding.
- 2) Manual adjustment to recover the machine under emergency conditions.

10. *Maintenance; Maintenance check lists;*

Normal maintenance

- Removal of air from the hydraulic system if the product is left unused for long periods of time.

11. *Ease of accessibility and replacing of internal parts;*

Replacement of parts should only be carried out by appropriately trained and competent persons.

If parts require replacement only replace the whole components such as hoses, hydraulic cylinders or load holding and over centre valve.

Do not attempt maintenance of hydraulic components i.e. replace seals or internal component.

Only Niftylift original and supplied parts shall be used.

12. *Means for easy and safe trouble shooting;*

Elevate the luffing booms and check that the cage remains level and the booms remain in their elevated position. If the cage does not remain level the system should be serviced by trained persons fully conversant with the function of the system.

13. *Information explaining the applications for use relevant to the category to which reference is made;*

Not applicable

14. *Checking test intervals where relevant.*

Check the operation of the load holding system to be made at the beginning of every duty cycle.

Operating & Safety Instructions

A7 INTERLOCKING OF TRAVEL CONTROLS

The interlocking of the control positions is PL b in accordance with ISO 13849-1:2008 as required by BS EN 280:2013

1. The limits of the safety-related parts to the category selected and any fault exclusions;

The cage control block has internal circuitry which isolates all boom control commands if either the primary drive or steer segments are being used. The internal flow path is denied from the secondary functions when the first two segment levers are off their central flow path position. The base control position has no drive nor steer segments so the boom controls do not need this interlock function.

Proper maintenance and daily safety checks to be observed.

By virtue of the physical separation of the flow paths, the drive and steer functions will always have priority over any boom function. Consequently the boom controls can be interrupted at any time by inadvertent operation of either drive or steer. **Reasonably foreseeable misuse.**

2. The limits of the SRP/CS and any fault exclusion, for which, when essential for maintaining the selected category or categories and safety performance, appropriate information (e.g. for modification, maintenance and repair) shall be given to ensure the continued justification of the fault exclusion(s);

Do not alter, modify or disable in any way the controls, safety devices, interlocks or any other part of the machine.

Maintenance must only be carried on by appropriately trained and competent persons, who are conversant with all modes of operation, speeds and characteristics of this model.

3. The effects of deviations from the specified performance on the safety function(s);

If the interlocking of the travel controls does not function as intended it is possible that the Niftylift may allow modes of operation that render it potentially dangerous.

If the controls do not remain independent in their operation, damage to the Niftylift, other equipment and properties, injury or loss of life of the operator and surrounding persons may be a risk.

4. Clear descriptions of the interfaces to the SRP/CS and protective devices;

The internal flow path that supplies pressure to the subsidiary functions for all boom controls is interrupted by the use of tether the drive or steer segment. No flow is then available for any boom movement as long as either of the two previous segments are away from their central rest position.

5. Response time

Loss of the boom functions is immediate as soon as a drive or steer function is selected.

6. Operating limits (including environmental conditions);

All components within the travel control interlock system are rated to the environmental conditions acceptable for the machine; see **Section 2.2**

7. Indications and alarms;

None.

8. Muting and suspension of safety functions;

None.

9. Control modes;

Moving the control lever for drive or steer away from the central rest position immobilises the boom control lever functions. No flow is made available for any segment to the right of the drive/steer controls.

10. Maintenance; Maintenance check lists;

Normal maintenance

- Visual check of all levers including the mechanical links from the levers to the valve spools.
- Ensure the smooth and uninterrupted operation of the two-axis drive steer function, especially the rose joints on the manipulator.
- Check the loss of functions for all boom movements with the machine steer lever operated and held to one end of travel. No boom functions should be available if the steer lever is away from the central rest position. Repeat for drive, but when doing so, be aware of the possibility of the machine moving as the control functions are checked. This should be performed in a clear, open area.

11. Ease of accessibility and replacing of internal parts;

Replacement of parts should only be carried out by appropriately trained and competent persons.

Only Niftylift original and supplied parts shall be used.

12. Means for easy and safe trouble shooting;

To check the operation of the travel control interlock.

1. Power on the Niftylift and select the cage control location.
2. Allow the power circuits to cycle and ensure the machine is ready for the command signal.
3. Press the base green button and operate a boom function to raise.
4. At the same time, operate the control lever to steer the drive wheels in one direction of the other.
5. Observe that the boom control function is lost and does not return until the steer lever is released.
6. In a clear area, repeat for a drive forward/ drive backward lever function whilst operating a boom raise command.
7. Observe that the boom control function is lost and does not return until the drive lever is released.
8. Power off the Niftylift.

13. Information explaining the applications for use relevant to the category to which reference is made;

Not applicable

14. Checking test intervals where relevant.

Check the operation of the travel control interlock to be made at every service interval.

niftylift