



Rough Terrain Self-propelled Scissor Lift

GS™-2668 RT

A reliable rough terrain scissor lift with superior gradeability and standard four wheel drive.



GS-2668 RT

- Four wheel drive, rough terrain design handles rugged construction job sites.
- Heavy-duty square steel guardrails
- Large platform deck with 60 inches (251 cm) of roll-out extension and durable diamond plate aluminum flooring.
- High angle steering provides excellent maneuverability.
- Swing-out engine tray allows easy access to components.

Standard Features

- Four wheel drive
- Gas/LPG and Diesel power options
- 32 ft (9.75 m) working height
- 60 in (251 cm) roll-out platform extension
- 68 in (1.72 m) unit width
- 1,250 lbs (567 kg) load capacity
- 40% gradeability
- 4 mph (6.4 km/h) maximum drive speed
- High speed/high torque selector switch
- Proportional drive
- Two-speed lift functions
- AC outlet in platform
- Multiple disk brakes
- Manual platform lowering valve
- Tilt sensor with an audible alarm
- Emergency stop switches at platform and ground controls
- Manual brake release
- Swing-out engine tray
- Automotive horn
- Full height swing platform gate
- Foam-filled tires
- Hour meter

Options and Accessories

- Motion alarm
- Air line to platform
- Dual flashing beacon
- 2,000 watt AC generator
- Head and tail lights
- Platform work lights
- Powered deck extension
- Spare propane tank
- Pressure gauge, water temperature gauge and voltage meter

Standards Compliance

- ANSI/SIA A92.6
- CSA CAN3-B354.2-M82
- CE compliance option

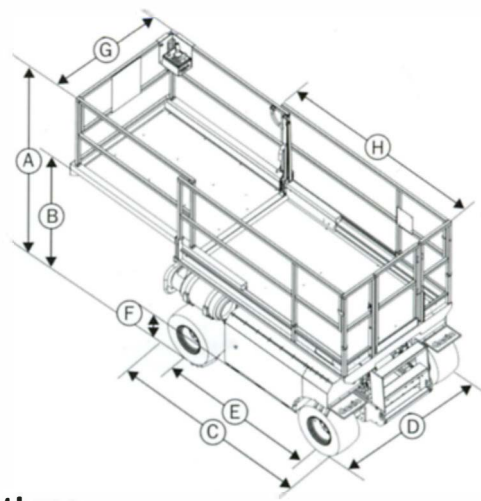

Specifications

Model	GS-2668 RT	
	US	Metric
Working height	32 ft	9.75 m
Platform height	26 ft	7.92 m
(A) Height - stowed (guardrails)	91 1/2 in.	232.41 cm
Height - stowed (guardrails lowered)	65 in	165.1 cm
(B) Height - stowed (platform)	47 in	119.38 cm
(C) Unit length - stowed	105 in	266.70 cm
Unit length, platform extended	165 in	419.10 cm
(D) Unit width	68 in	172.72 cm
(E) Wheelbase	73 in	185.42 cm
(F) Ground clearance	8 in	20.32 cm
(G) Platform width	61 in	154.94 cm
(H) Platform length - stowed	99 in	251.46 cm
Platform length - extended	159 in	403.9 cm
Roll-out platform extension	60 in	251 cm
Lift capacity	1,250 lbs	567 kg
Extension deck capacity	300 lbs	136 kg
Turning radius outside	145 in	368.30 cm
Turning radius inside	60 in	152.40 cm
Power source	Kubota 23 HP/LPG Kubota 20 HP diesel	
Drive speed - stowed	4.0 mph	6.4 km/h
Drive speed - raised	0.7 mph	1.1 km/h
Raise/lower speed	30/24 sec	
Controls	proportional drive	
Tire width	12 in	30.48 cm
Tire Diameter	26 in	66.04 cm
Gradeability	40%	
Drive	four wheel	
Multiple disc brakes		
Weight	6,550 lbs	2,971 kg

Distributed By:

Genie Industries

GENIE UNITED STATES

18340 NE 76th Street
P.O. Box 97030
Redmond, Washington 98073-9730
Telephone (425) 881-1800
Toll Free in USA/Canada 800-536-1800
Fax (425) 883-3475
<http://www.genielift.com>

GENIE UNITED KINGDOM

Brunel Drive
Newark
Nottinghamshire
NG24 2EG England
Telephone (44) 01636-605030
Fax (44) 01636-611090
<http://www.genielift.com>